

RCI-72-24-001-2: R1S Supplemental Restraint System (SRS) Overview and Servicing Guidelines

Rivian Automotive, LLC - Service Guideline

Document Type	Collision Repair Information Document
Date	March 29, 2024
Affected Region(s)	USA
Affected Model(s)	R1S
Model Year(s)	2022+
Vehicle System	72 - Occupant Protection

Important:

- This procedure requires RiDE. Review the RiDE instructions specific to this procedure before starting work.
- Some RiDE routines are restricted and will need to be performed by a Rivian service center.

Attention:

- This document is intended as a general Supplemental Restraint System (SRS) component overview and servicing guideline. Always refer to the Rivian Service Manual for vehicle specific information when servicing or replacing SRS components.
- Rivian recommends that only Factory Certified Service Technicians inspect and repair the SRS System in Rivian vehicles. Please contact your regional Rivian Collision/Service Team to request more information or assistance with repairs.
- For more information, refer to the following service procedure: [Component Inspection and Replacement After Airbag Deployment](#)

General Information

In an effort to promote and maintain its rigorous standards of quality and safety, Rivian Automotive provides the collision industry with important information regarding the various components that make up the Supplemental Restraint System (SRS) of Rivian Vehicles, and best practices to use after a collision event.

SRS Components

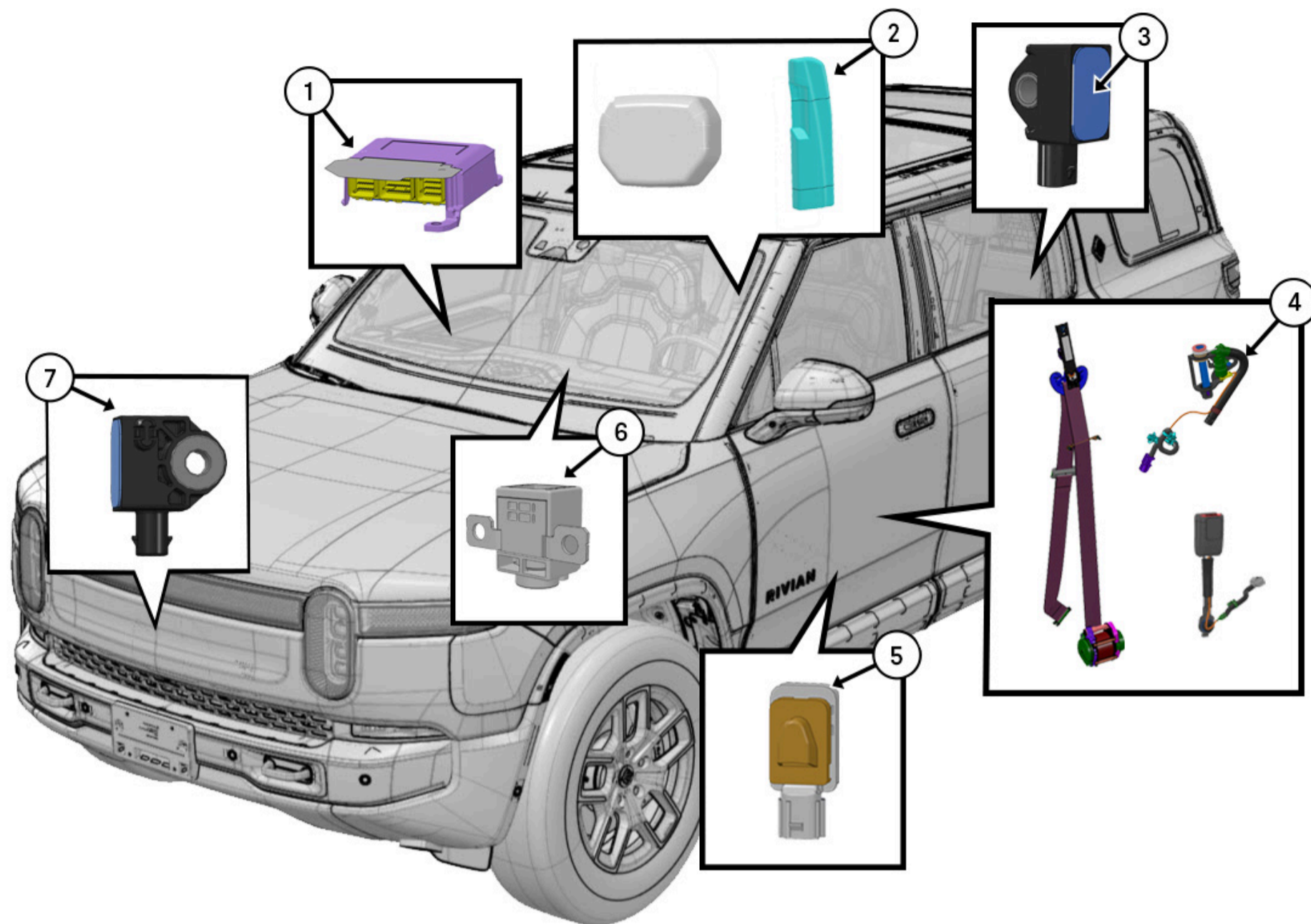

Callout	Component
1	Restraint Control Module (RCM)
2	Airbag Modules
3	Safing Sensors
4	Seatbelts, Pre-tensioners and Buckles
5	Pressure Sensors
6	Pyrotechnic Fuse
7	Acceleration Sensors (G-Sensors)

SRS Best Practices after a Collision Event

Attention:

Disable the 12V system per the procedure in the service manual, prior to replacing any SRS components. Allow approximately one minute after disabling the system before working on, or near, any SRS component(s).

Important:

- Always review all service information regarding SRS systems prior to starting repairs.
- Always clean interior vehicle surfaces after a deployment event prior to starting repairs.
- Always treat all SRS components as live, regardless of condition.

Note:

Multi-stage SRS devices may appear fully deployed but could still hold active charges.

- Always refer to the service manual for all current and up to date repair information regarding SRS systems prior to performing any repairs.
- Always make sure the area around the SRS component being serviced is clean and free from any obstructions.

- Always make sure new SRS components remain stored in their packaging until ready for installation.
- Always make sure to store removed SRS components in a safe location.
- Always inspect new SRS components prior to installation to make sure they are free from defects or damage.
- Always make sure to cover all SRS electrical connectors during repairs.
- Always install new SRS components using new fasteners.
- Always refer to the electronic parts catalog for available pins, wiring, locking tabs, or weather seals commonly used in SRS component wiring.
- Never install any damaged, contaminated, aftermarket, or used SRS components.
- Never drop the pressure sensor, expose the pressure sensor to compressed air, or repair materials.
- Never tamper with or cut the wiring harnesses for the driver's airbag, side airbag, roof rail airbag, or seat belt pre-tensioners, to avoid a possible deployment.
- Never use test lights, Volt Meters, Ohm Meters, or any tool that has the ability to probe connectors on SRS components.

Note:

Only the Rivian Diagnostic Environment (RiDE) tool should be used for diagnosis and to access system functions.

Restraint Control Module (RCM)

Attention:

RCM replacement is required after deployment of any SRS component.

Important:

- Never install a new, or removed, RCM module if it has been dropped or mishandled in any way.
- Always replace the RCM after the deployment of any SRS component.
- Always make sure replacement SRS components remain stored in their packaging until ready for installation.
- Always inspect removed modules for pin, connector or wiring harness damage.

Note:

Perform only allowable repairs as outlined in the service manual, prior to installation of the new or removed RCM.

- Always use new fasteners when installing the replacement RCM in the vehicle.

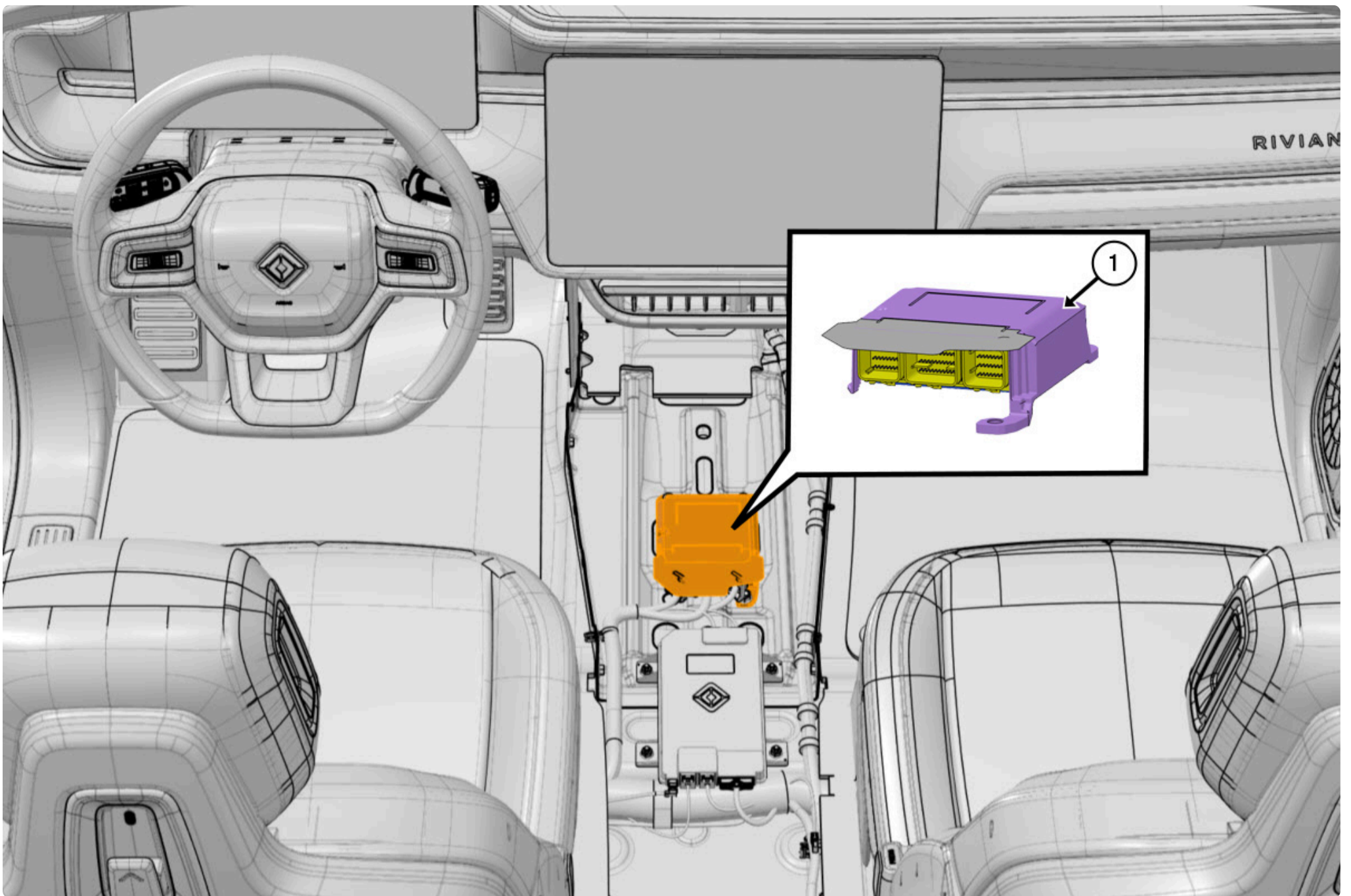

Callout	Component
1	RCM

Airbag Modules

Attention:

Restraint Control Module (RCM) replacement is required after deployment of any SRS component.

Component Replacement after airbag deployment:

- **Steering Wheel Airbag:** Replace airbag module, steering wheel, clock spring assembly, and steering column assembly.
- **Steering Column:** Inspect the front dash bar when replacing the steering column. Replace dash bar if any cracks or excessive movement is visible. Additionally, inspect surrounding instrument panel structure for any damage and replace all damaged components.
- **Seat-Mounted Side Airbag (SAB):** Replace the driver's seat back assembly, or the entire seat assembly, depending on the extent of the damage due to deployment. Never attempt a repair to the driver's seat back or the driver's seat assembly.
- **Side Curtain Airbag:** Replace headliner, side trim panels, metal brackets, handles, and associated clips.

Note:

Prior to installation of the curtain air bag module, inspect the pillar and roof mounting surfaces for damage. Make sure to confirm proper body sealing after component installation.

- **For all Airbags:** Always use new fasteners when installing the new airbag component.

Note:

Steering wheel airbag is a snap-in design and does not use any fasteners.

Attention:

It is the responsibility of the shop performing the repair to properly dispose of any replaced SRS components.

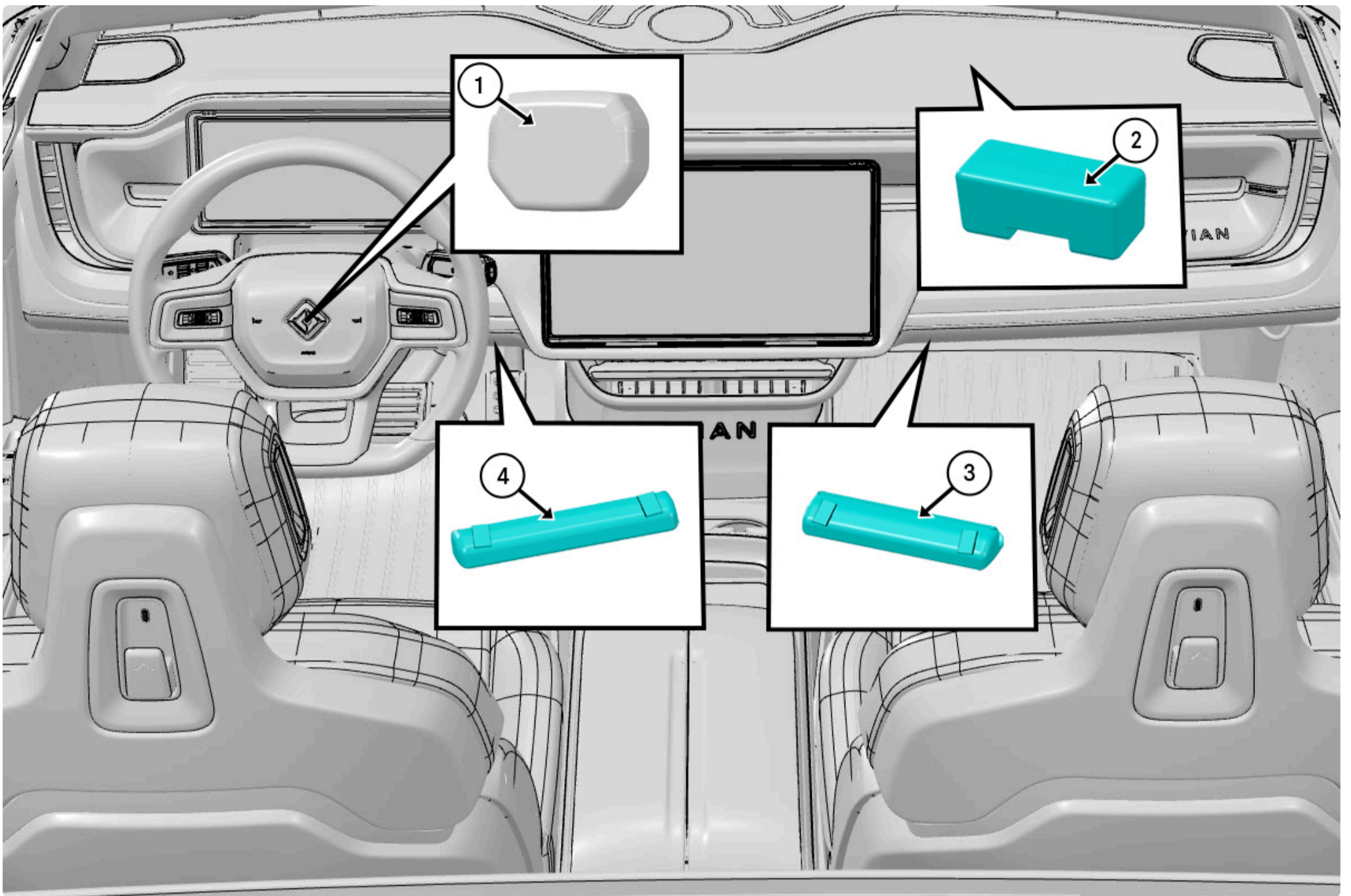

Callout	Component
1	Steering Wheel Airbag
2	Passenger Airbag
3	Passenger Knee Airbag
4	Driver's Knee Airbag

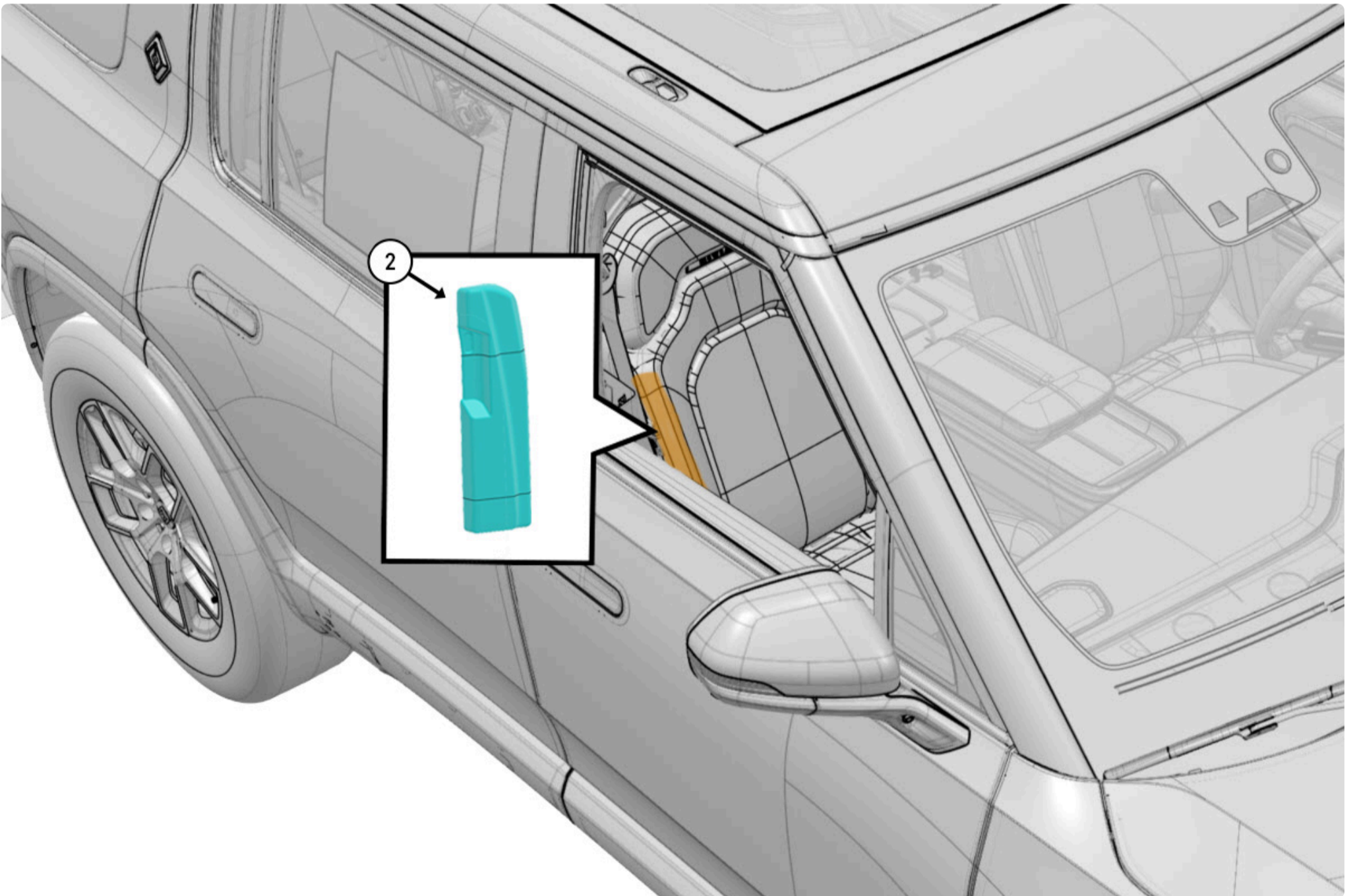
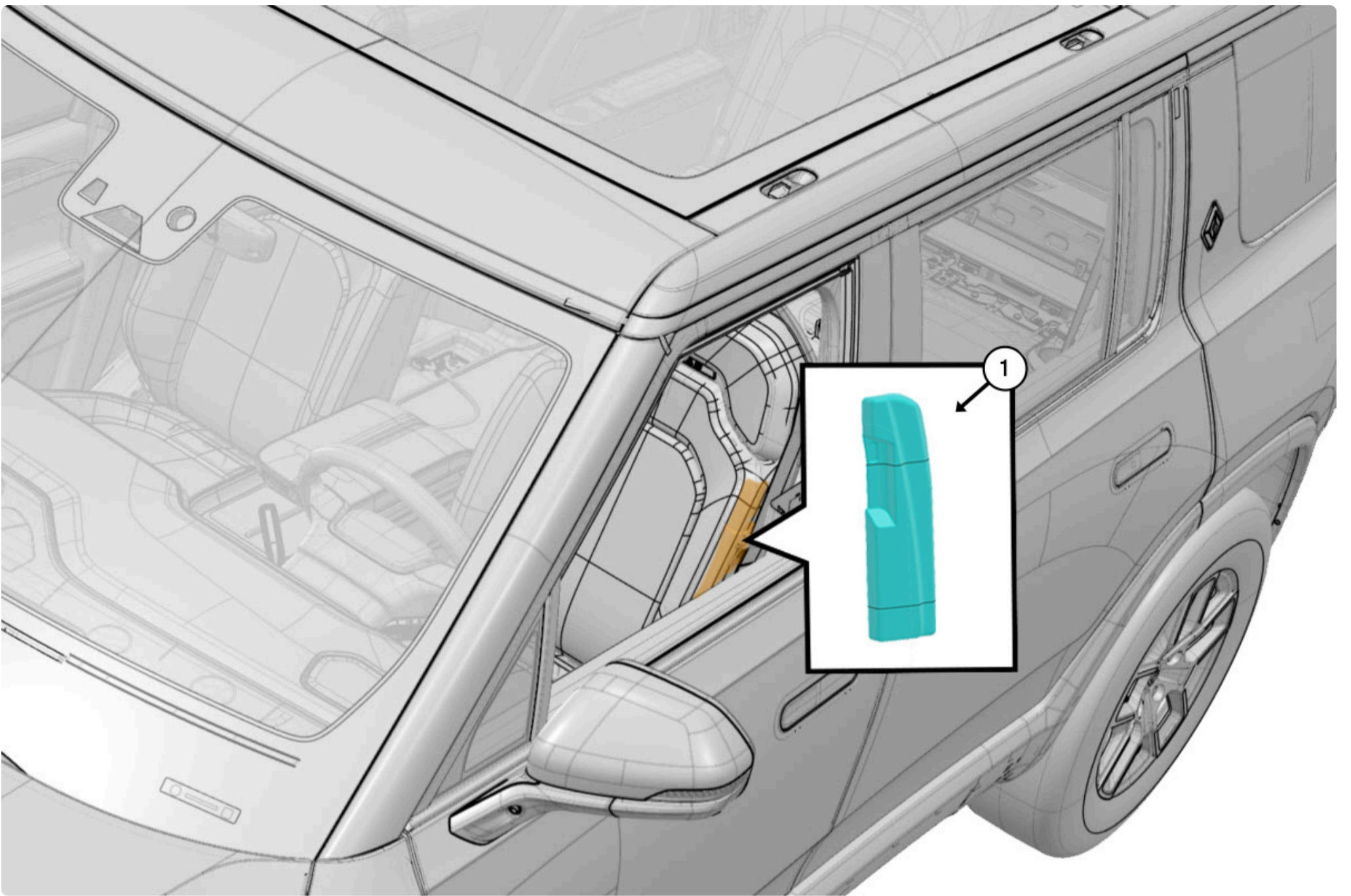

Callout

Component

Callout	Component
1	Seat-Mounted Side Airbag, Left
2	Seat-Mounted Side Airbag, Right

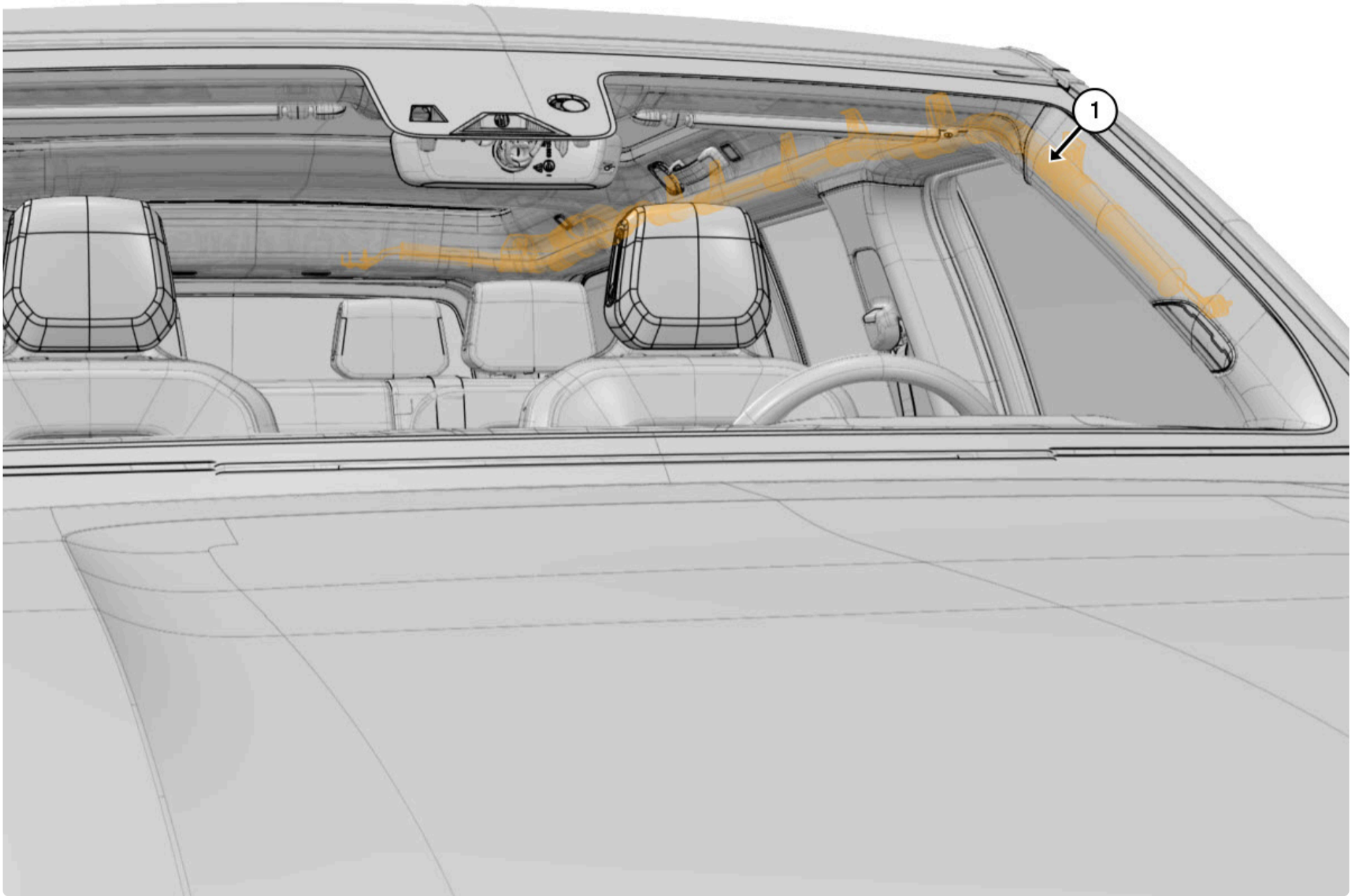

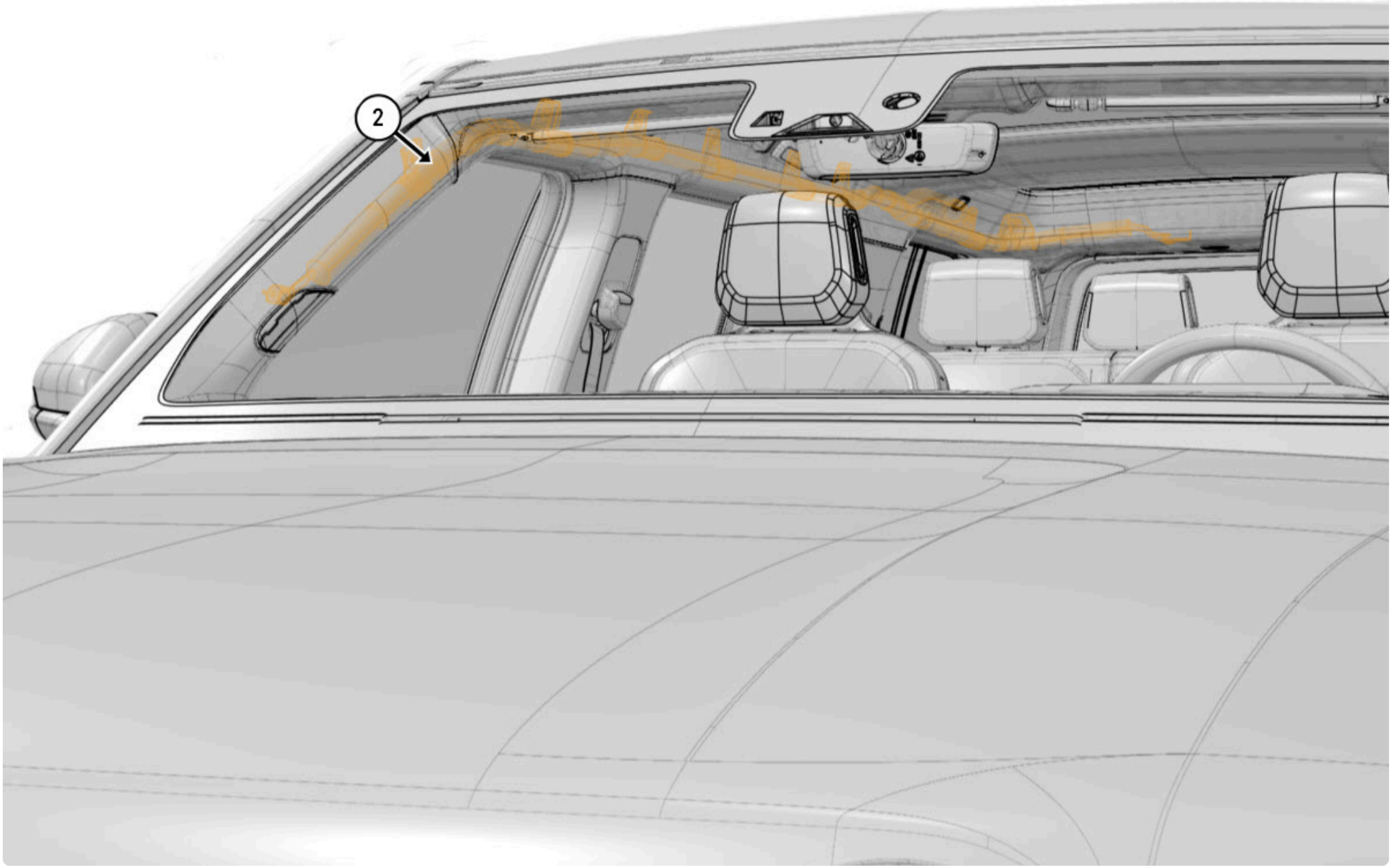

Callout	Component
1	Side Curtain Airbag, Left
2	Side Curtain Airbag, Right

Seatbelts, Pre-tensioners, and Buckles

Important:

- Never perform any internal repairs to the seatbelt assembly.
- Always inspect all seatbelt systems for damage after a collision event.
- Always replace the entire safety belt once it has been deployed during a collision event. This should include the seat belt, buckle, adjusters, pre-tensioner, fasteners, and sensor(s).
- Always replace the entire seatbelt assembly if any component(s) are damaged during installation.
- Always destroy and properly dispose of all replaced seatbelt assemblies.
- Occupant Detection Sensor replacement is not required in a deployment event unless seat damage is involved.

Attention:

It is the responsibility of the shop performing the repair to properly dispose of any replaced SRS components.

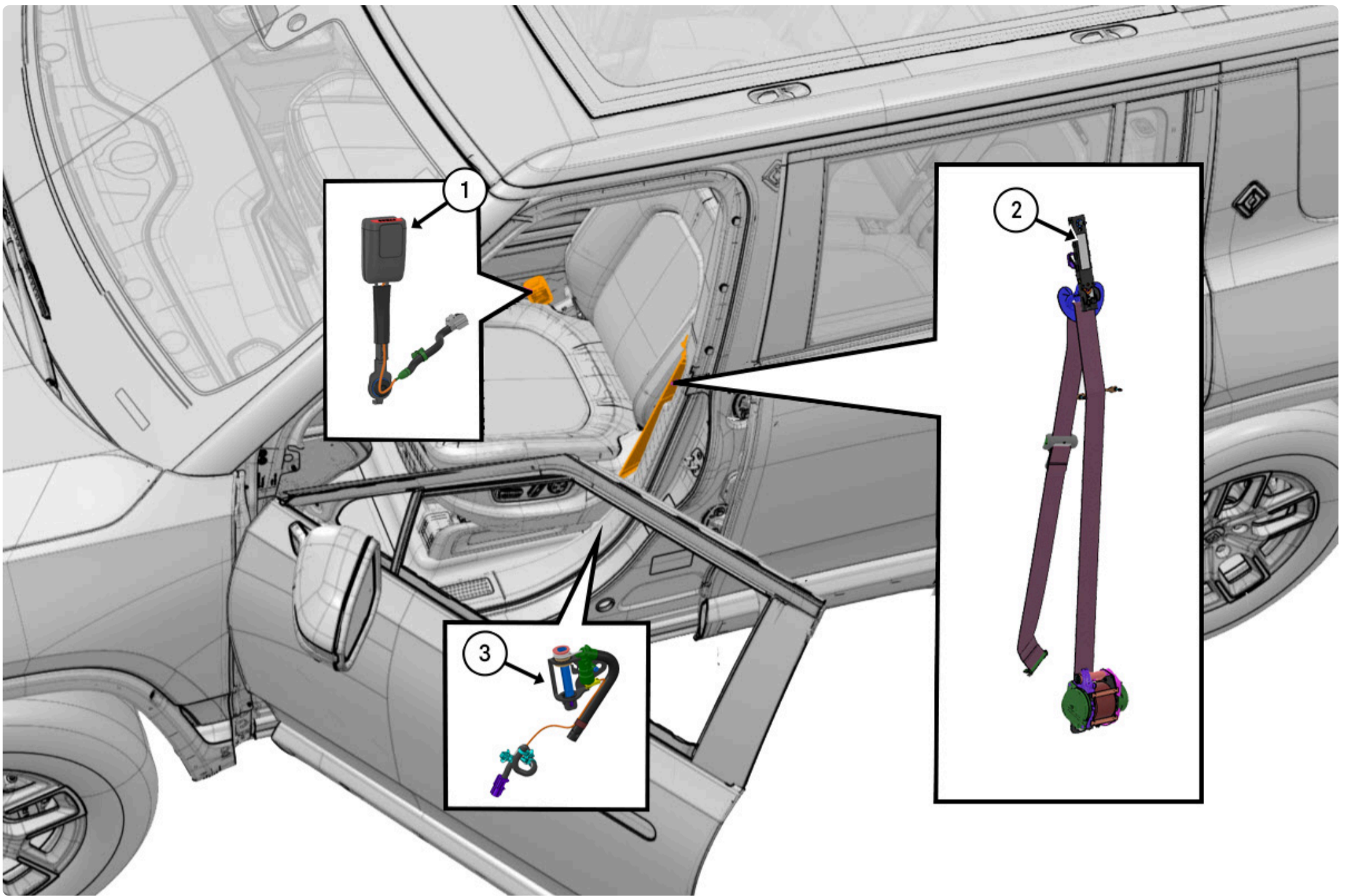

Callout	Component
1	Seatbelt Buckle (w/Sensor)
2	Driver's Seatbelt
3	Seatbelt Pre-tensioner

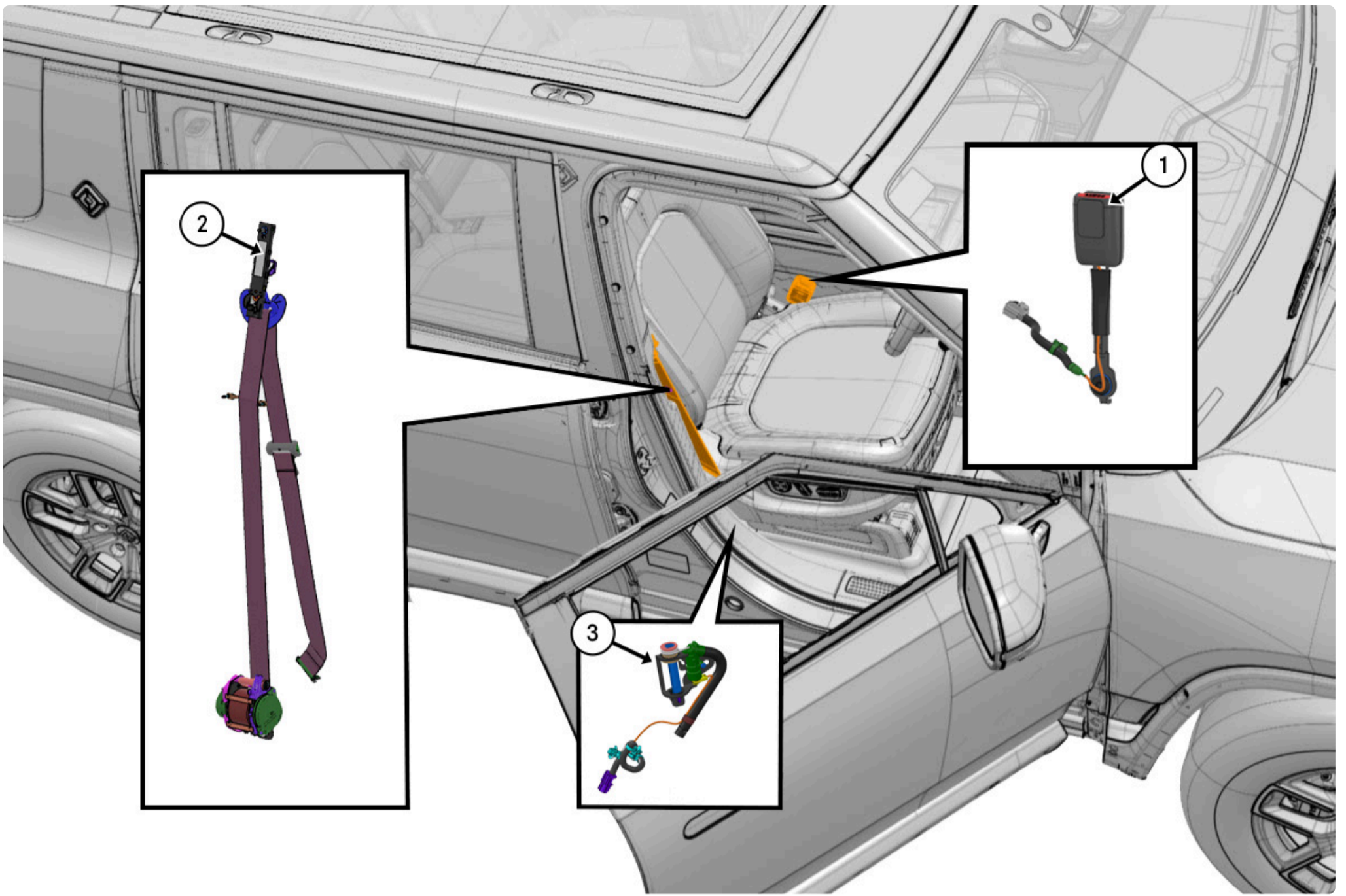

Callout	Component
1	Seatbelt Buckle (w/Sensor)
2	Passenger Seatbelt
3	Seatbelt Pre-tensioner

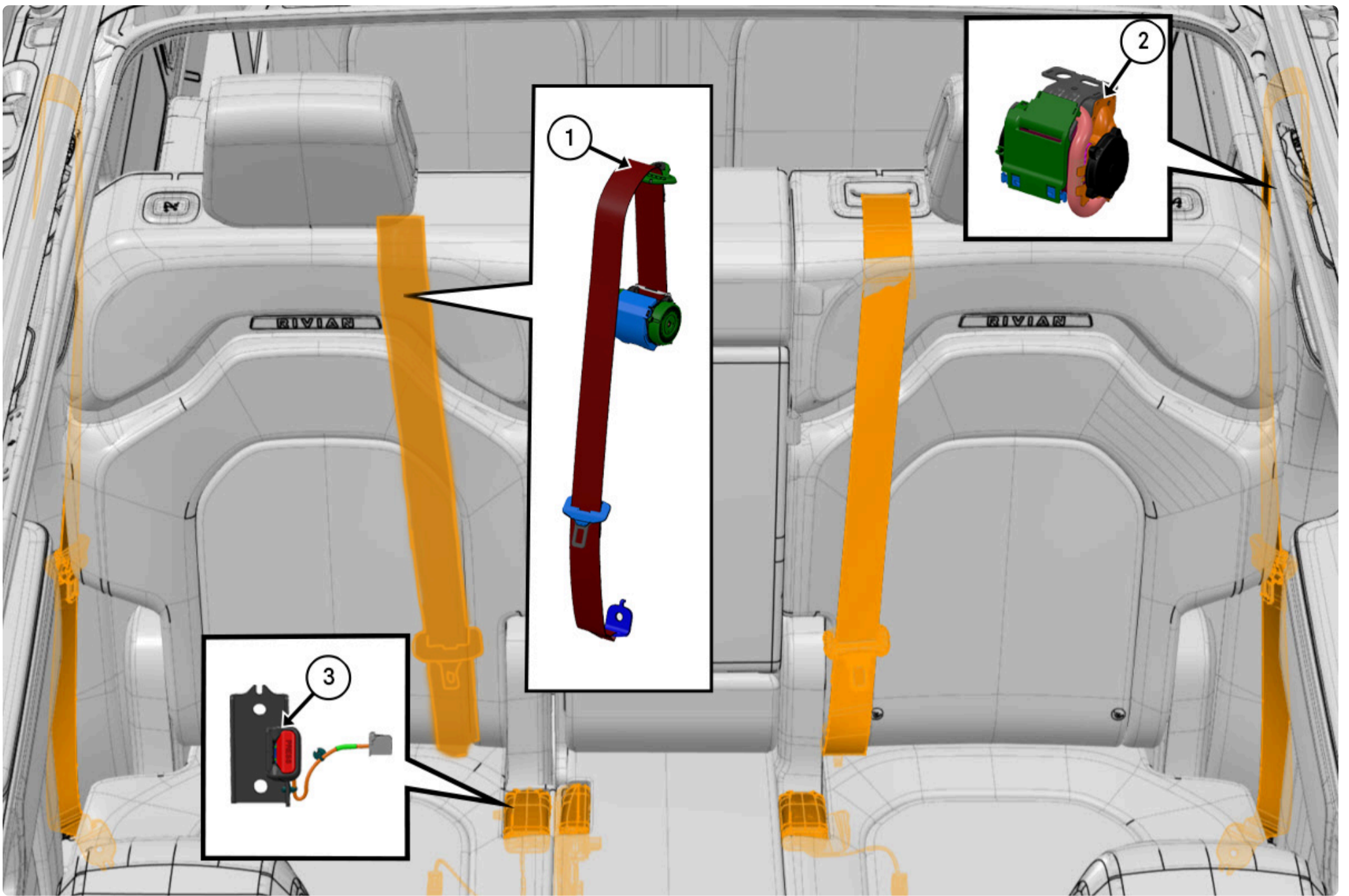

Callout	Component
1	Seatbelt Assembly, Rear
2	Seatbelt Pre-tensioner, Rear
3	Seatbelt Buckle (w/Sensor), Rear

Safing Sensors

Important:

- Never perform any repair(s) on a safing sensor.
- Never drop the safing sensor, expose the sensor to compressed air, or repair materials. Otherwise, safing sensor function and timing may be affected.
- Always replace any safing sensor mounted on a damaged panel to ensure proper and consistent function is preserved.
- Always use new fasteners when installing replacement safing sensors.

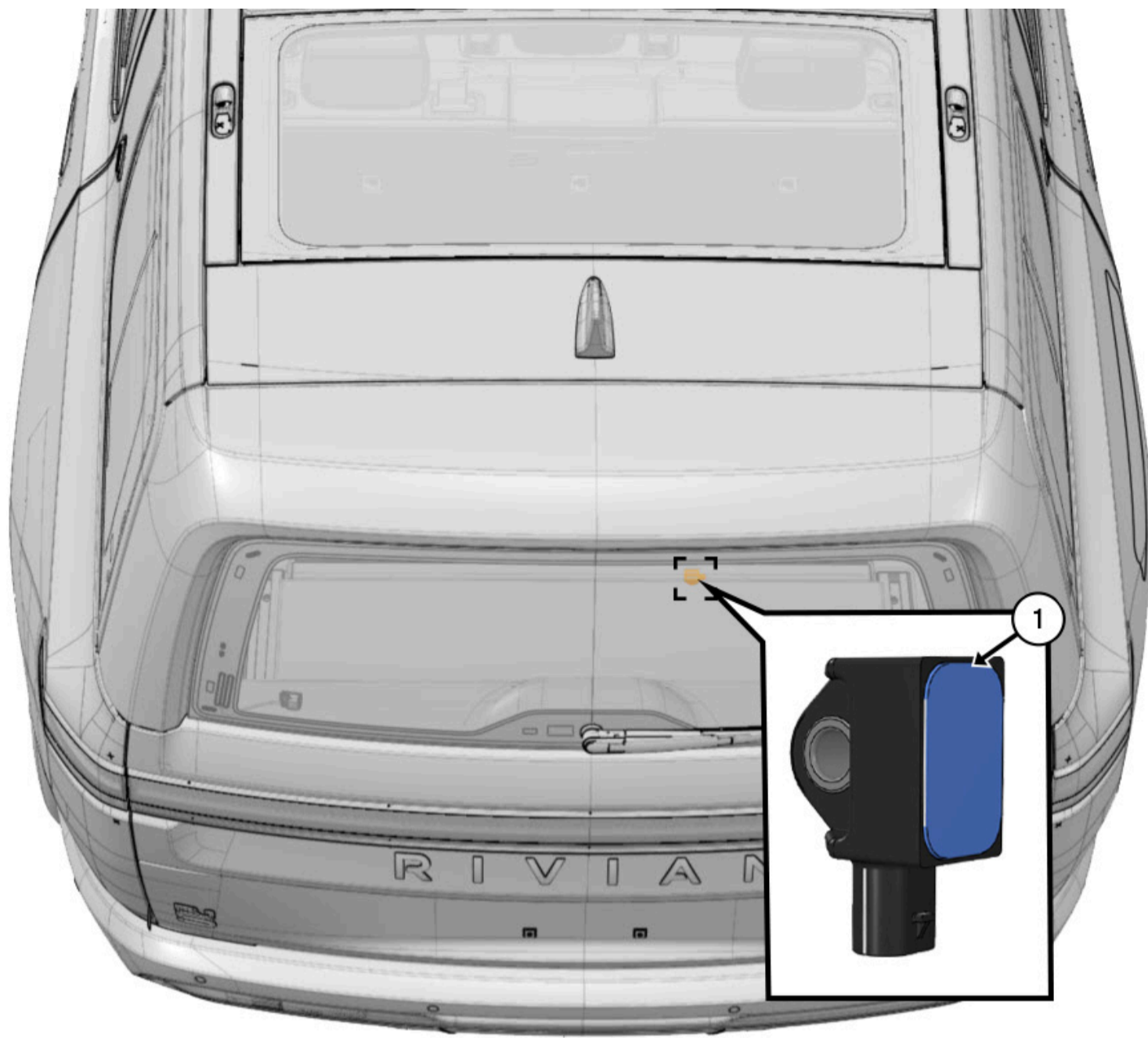

Callout	Component
1	Safing Sensor

Pressure Sensors

Important:

- Never perform any repair(s) on a pressure sensor.
- Never drop the pressure sensor, expose the sensor to compressed air, or repair materials. Otherwise, pressure sensor function and timing may be affected.
- Always replace the pressure sensor if there is damage to the panel on which the sensor is mounted and there has been a deployment, or, if damage has occurred to the inner panel in the area where the sensor is mounted.
- Always make sure that all proper internal door sealing is restored after performing any door repairs. Otherwise, pressure sensor function and timing may be affected.
- Always use new fasteners when installing replacement pressure sensors.

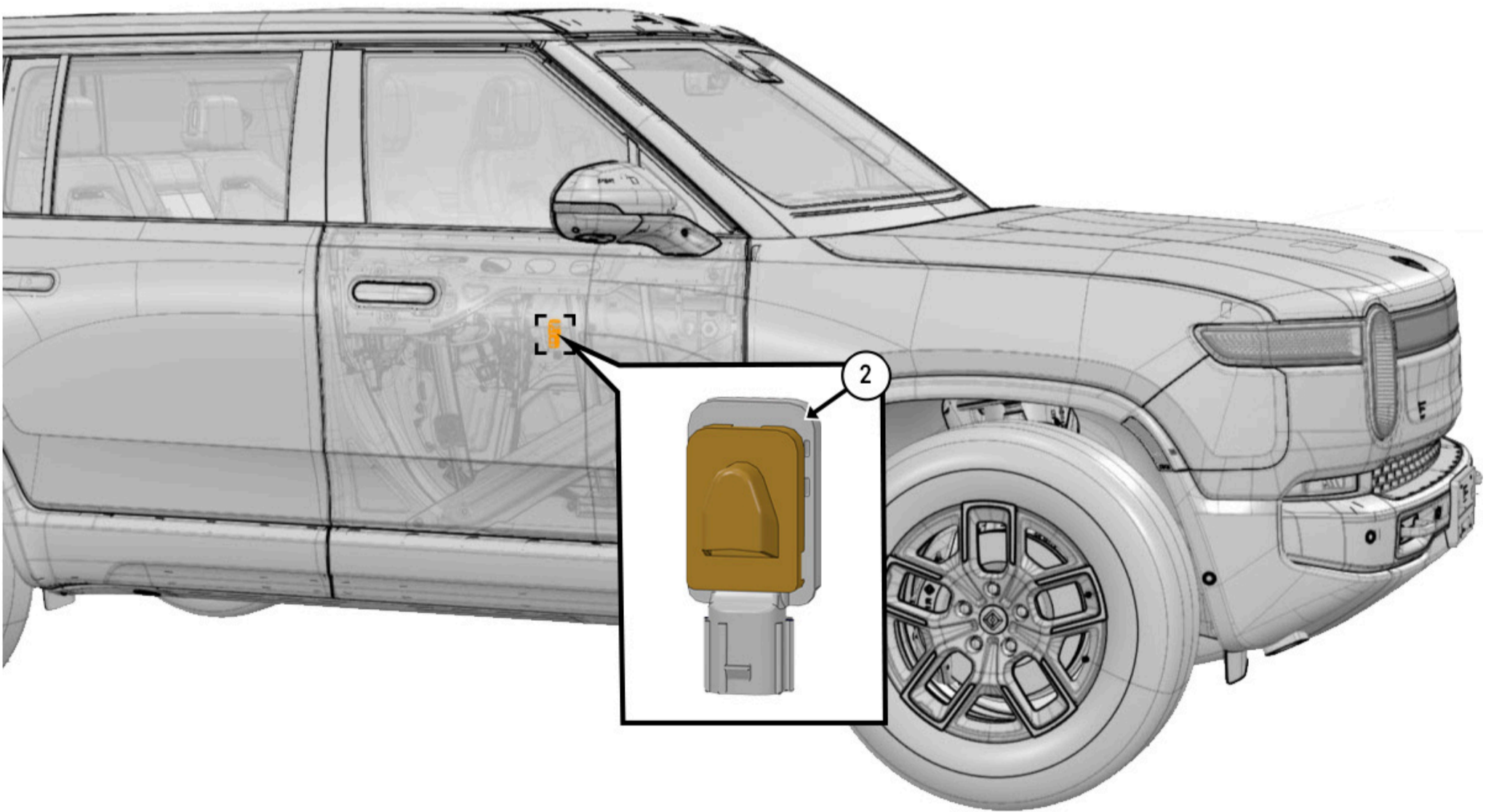
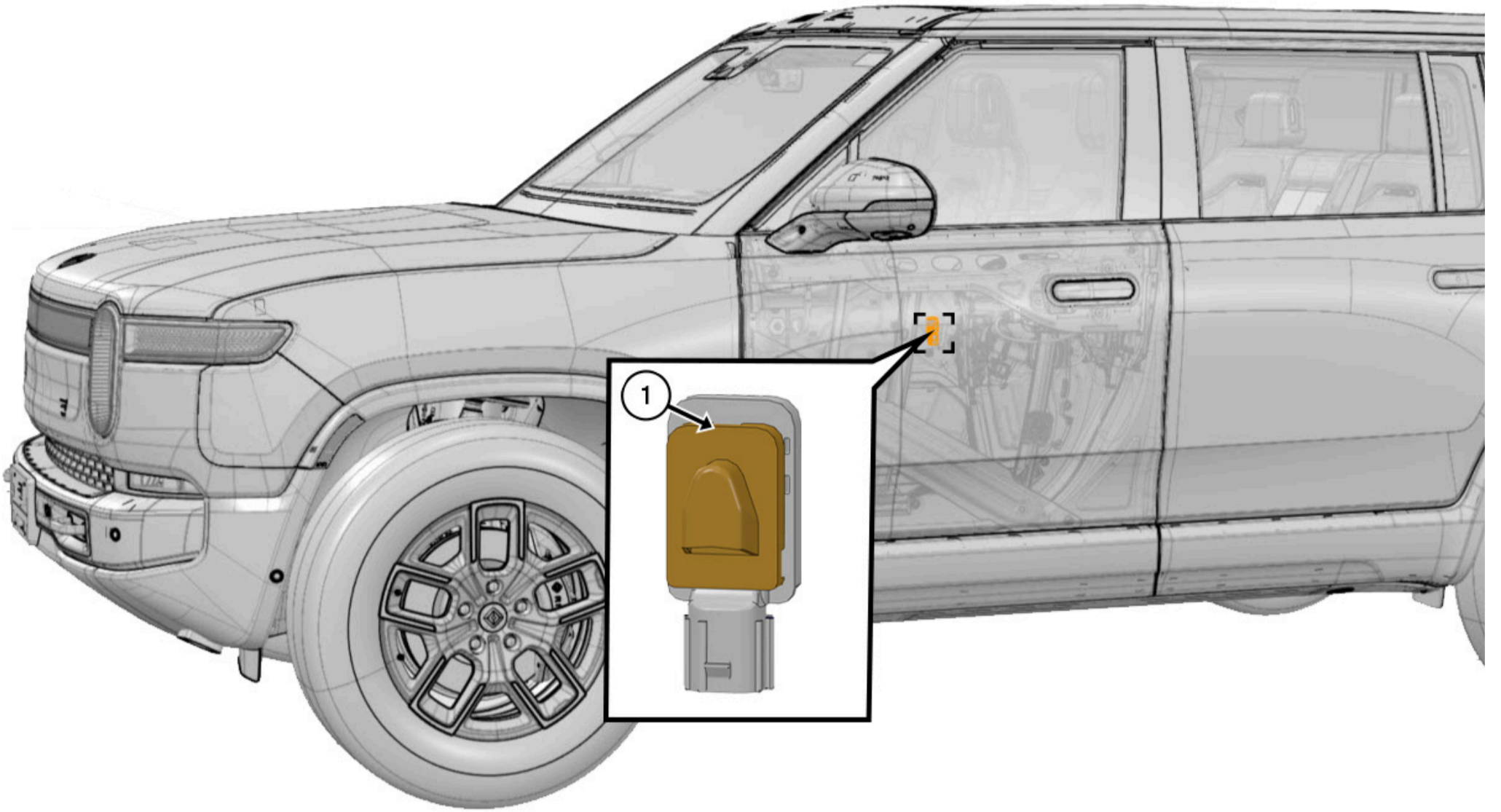

Callout	Component
---------	-----------

Callout	Component
1	Pressure Sensor, Left
2	Pressure Sensor, Right

Pyrotechnic Fuse

Replacement of the Pyrotechnic Fuse is required after airbag deployment. Damage to the HV system may also trigger the Pyro fuse, automatically disabling the HV system.

Attention:

The Pyrotechnic Fuse cannot be reset and requires replacement after it has been triggered. Refer to the following service manual procedure: [Switch, HV Disconnection, Pyrotechnic \(Remove and Replace\)](#).

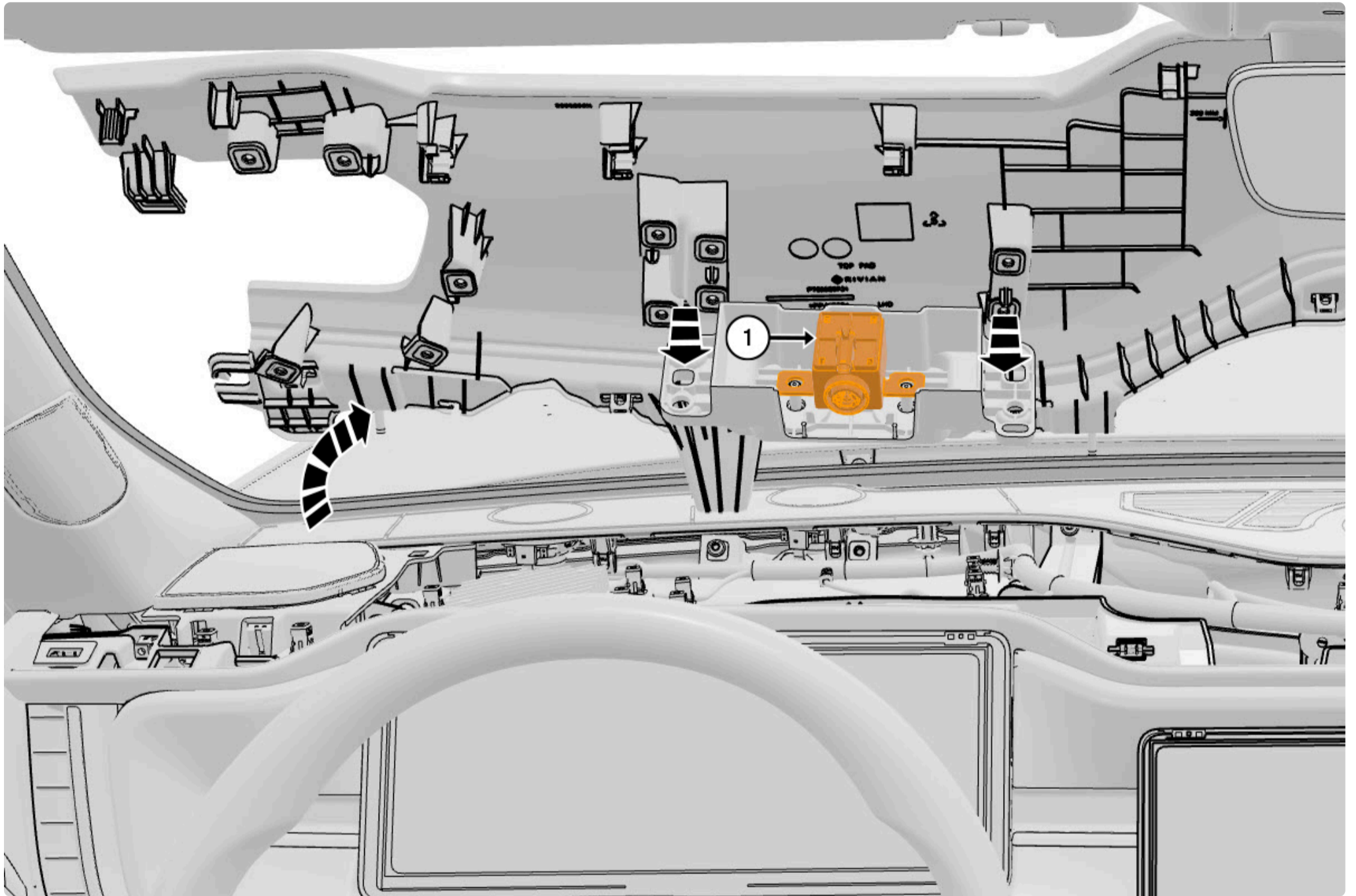

Callout	Component
1	Pyro Fuse

Acceleration Sensors (G-Sensors)

Important:

- Never perform a repair on an acceleration sensor. Damaged sensors must be replaced.
- Always replace any acceleration sensor mounted directly in the point of impact area.

Note:

Point of Impact is defined as the portion of the vehicle which is distorted, bent, or damaged due to impact or collision.

- Always replace any acceleration sensor if the mounting surface, or any fastener holding the sensor, is damaged or bent. Otherwise, acceleration sensor function may be negatively affected.
- Always perform a DTC scan/clear operation after acceleration sensor replacement.

- Always use new fasteners when installing replacement acceleration sensors.

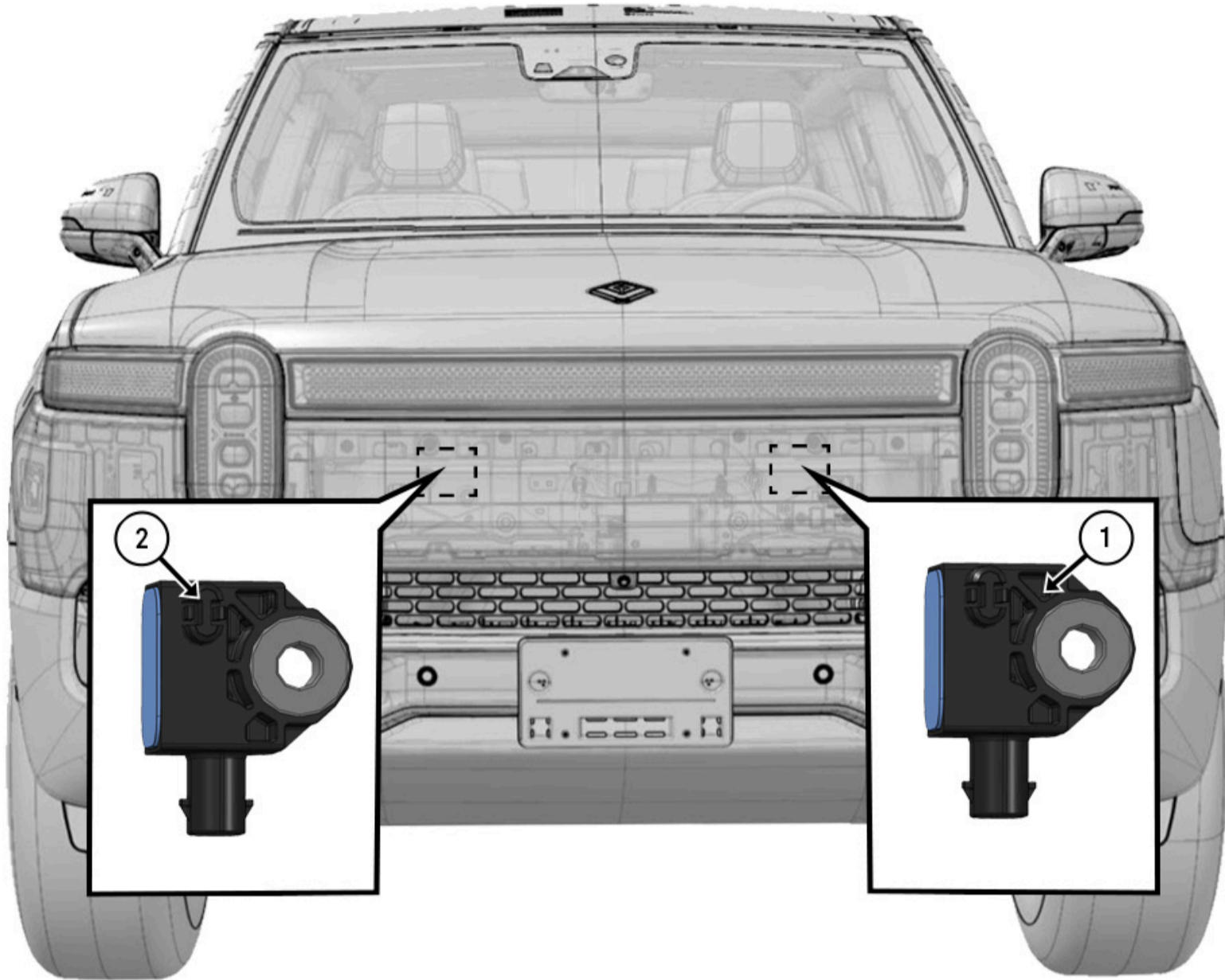

Callout	Component
1	Acceleration Sensor, Front, Left
2	Acceleration Sensor, Front, Right

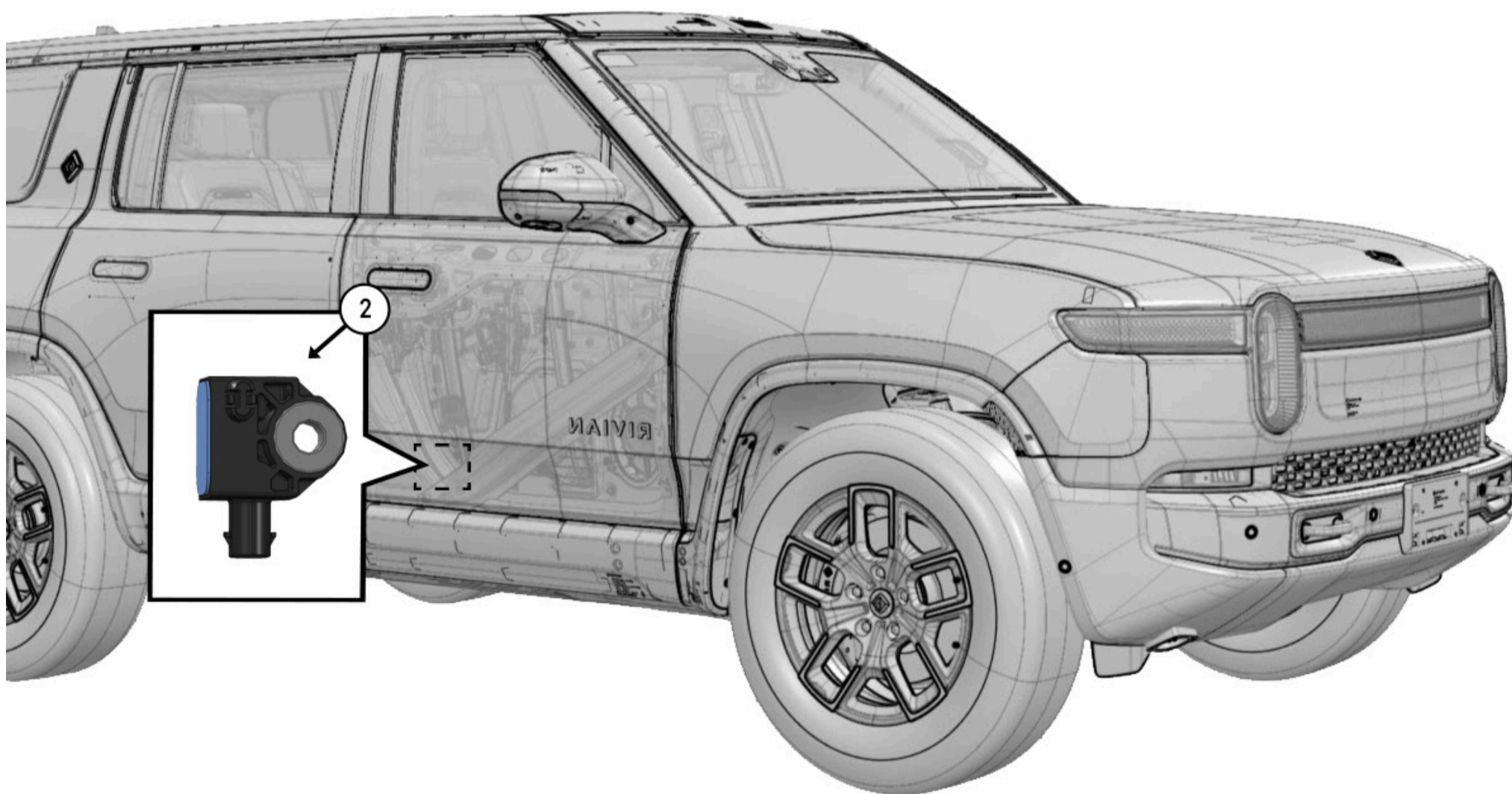
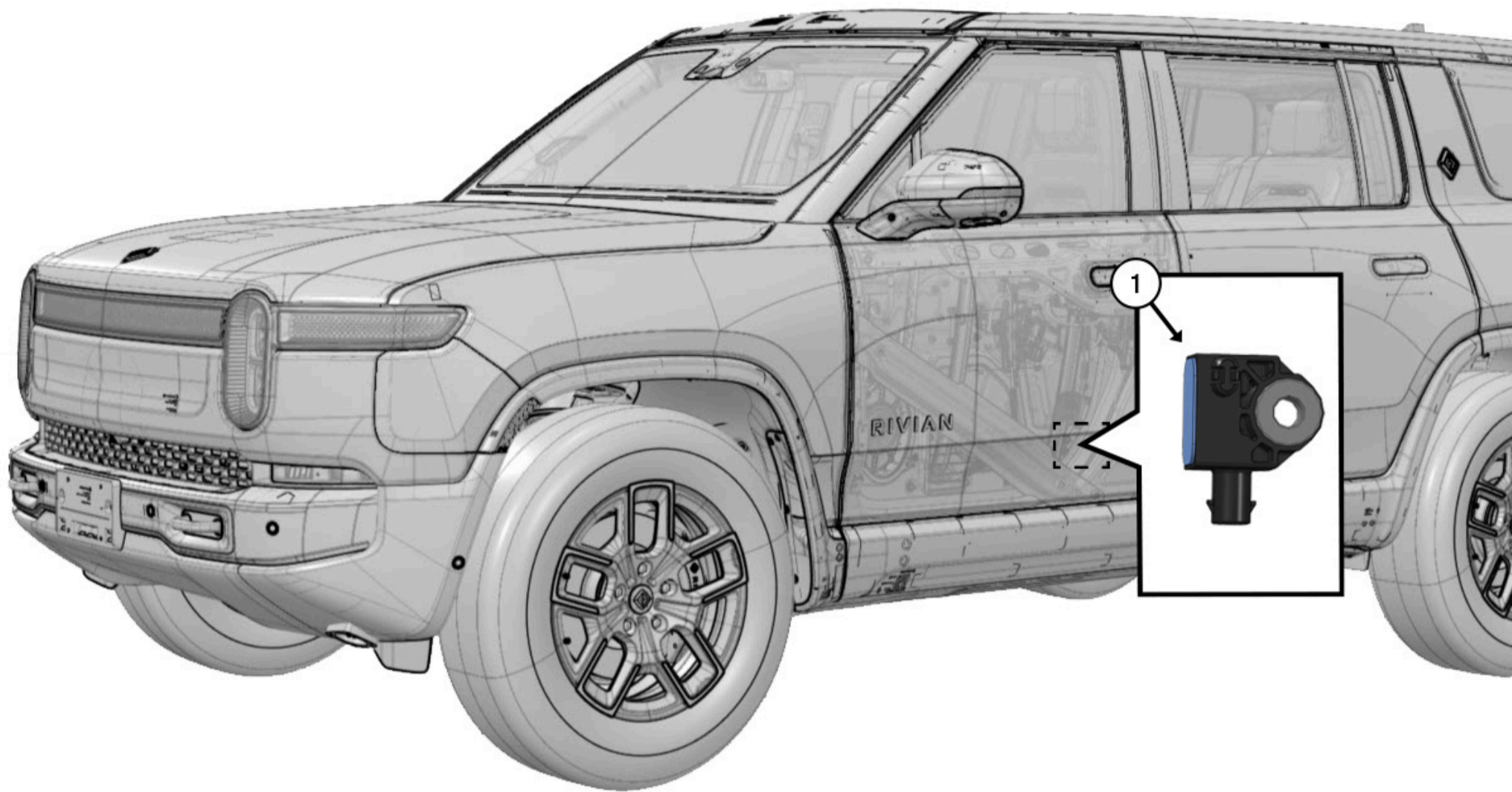

Callout	Component
---------	-----------

Callout	Component
1	Acceleration Sensor, B-Pillar, Left
2	Acceleration Sensor, B-Pillar, Right

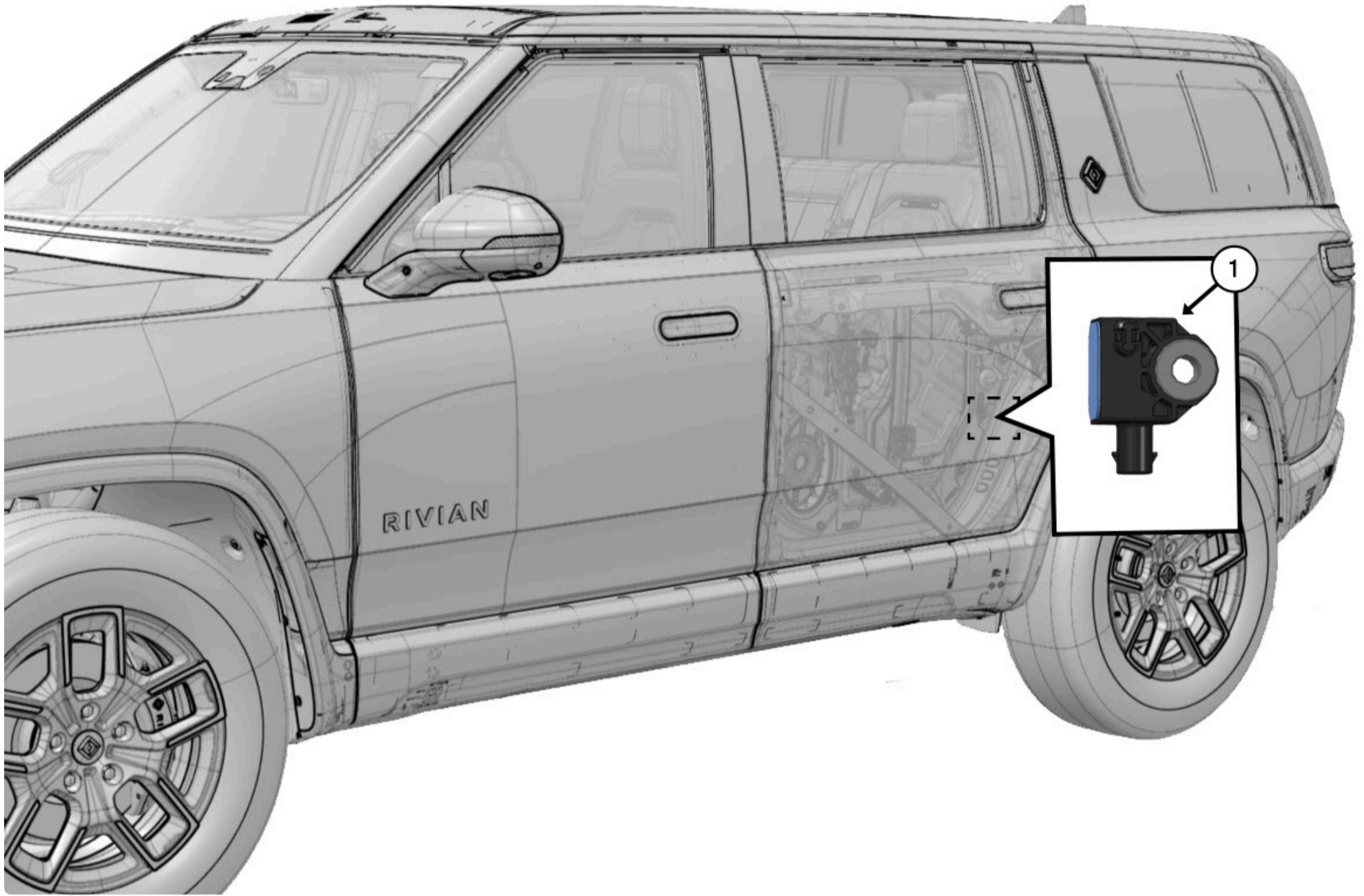

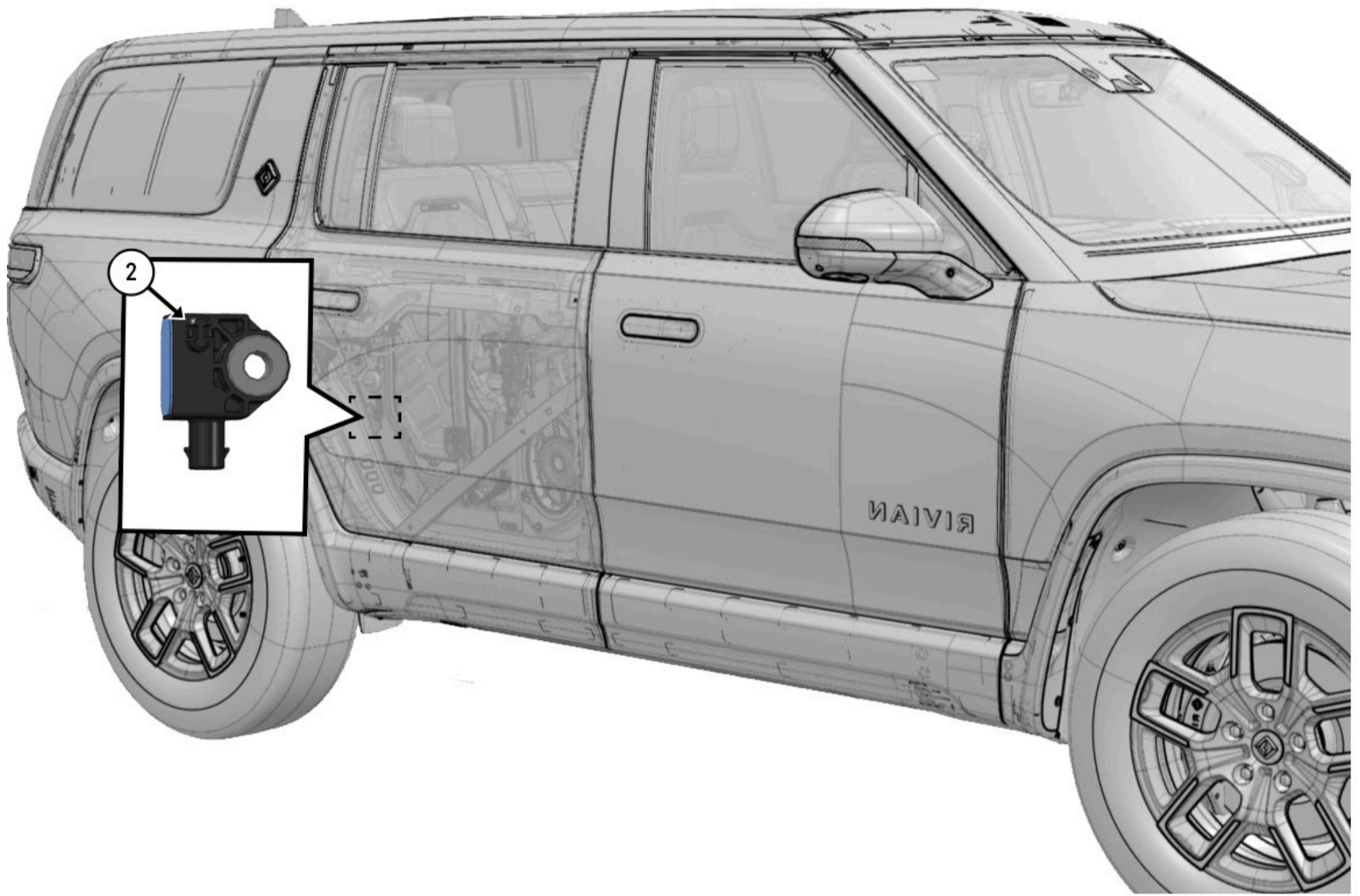

Callout	Component
1	Acceleration Sensor, C-Pillar, Left
2	Acceleration Sensor, C-Pillar, Right

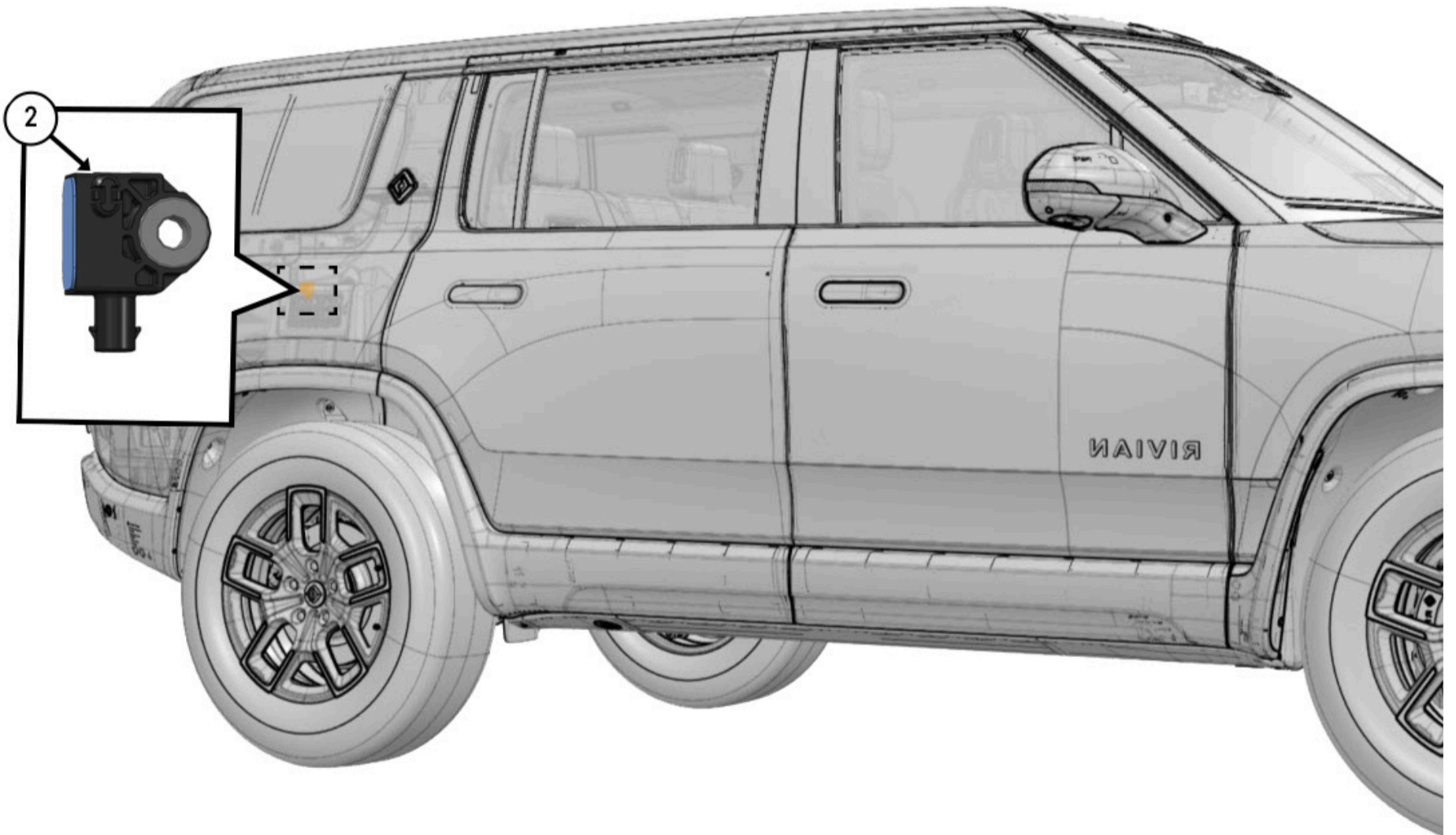

Callout	Component
---------	-----------

Callout	Component
1	Acceleration Sensor, D-Pillar, Left
2	Acceleration Sensor, D-Pillar, Right

SRS Component Inspection - Post Repair

- Always perform a seat belt operation check after all repairs have been completed.
- Always perform an SRS system inspection prior to returning the system to normal operation. For more information, refer to the following service procedure: [Component Inspection and Replacement After Airbag Deployment](#)

[Download a PDF copy of this document](#)