



## Information for First & Second Responders Emergency Response Guide For Vehicle:

Li-ion

2017–19 Honda Clarity Electric  
4-Door Sedan Electric Vehicle

**CLARITY**  
**ELECTRIC**



Version 1

This guide has been prepared to assist emergency response professionals in identifying a 2018–19 Honda Clarity Electric and safely respond to incidents involving this vehicle.

Copies of this guide and other emergency response guides are available for reference or downloading at <https://techinfo.honda.com>.

For questions, please contact your local Honda dealer or Honda Automobile Customer Service at **(800) 999-1009**.

Honda wishes to thank emergency response professionals for their concern and efforts in protecting Honda customers and the general public.



## Contents

1. Identification / Recognition	Page 04
2. Immobilization / Stabilization / Lifting	Page 10
3. Disable Direct Hazards / Safety Regulations	Page 13
4. Access to the Occupants	Page 16
5. Stored Energy / Liquids / Gases / Solids	Page 21
6. In Case of Fire	Page 23
7. In Case of Submersion	Page 24
8. Towing / Transportation / Storage	Page 25
9. Important Additional Information	Page 39
10. Explanation of Pictograms Used	Page 44

The Honda Clarity Electric can be identified by the **CLARITY** emblem mounted on the trunk and the **ELECTRIC** emblems mounted on the trunk and front fenders.

**CLARITY**

 **ELECTRIC**



Under the hood, the Honda Clarity Electric can be identified by the **ELECTRIC** emblem on power control unit (PCU) and the orange cables in the engine compartment.

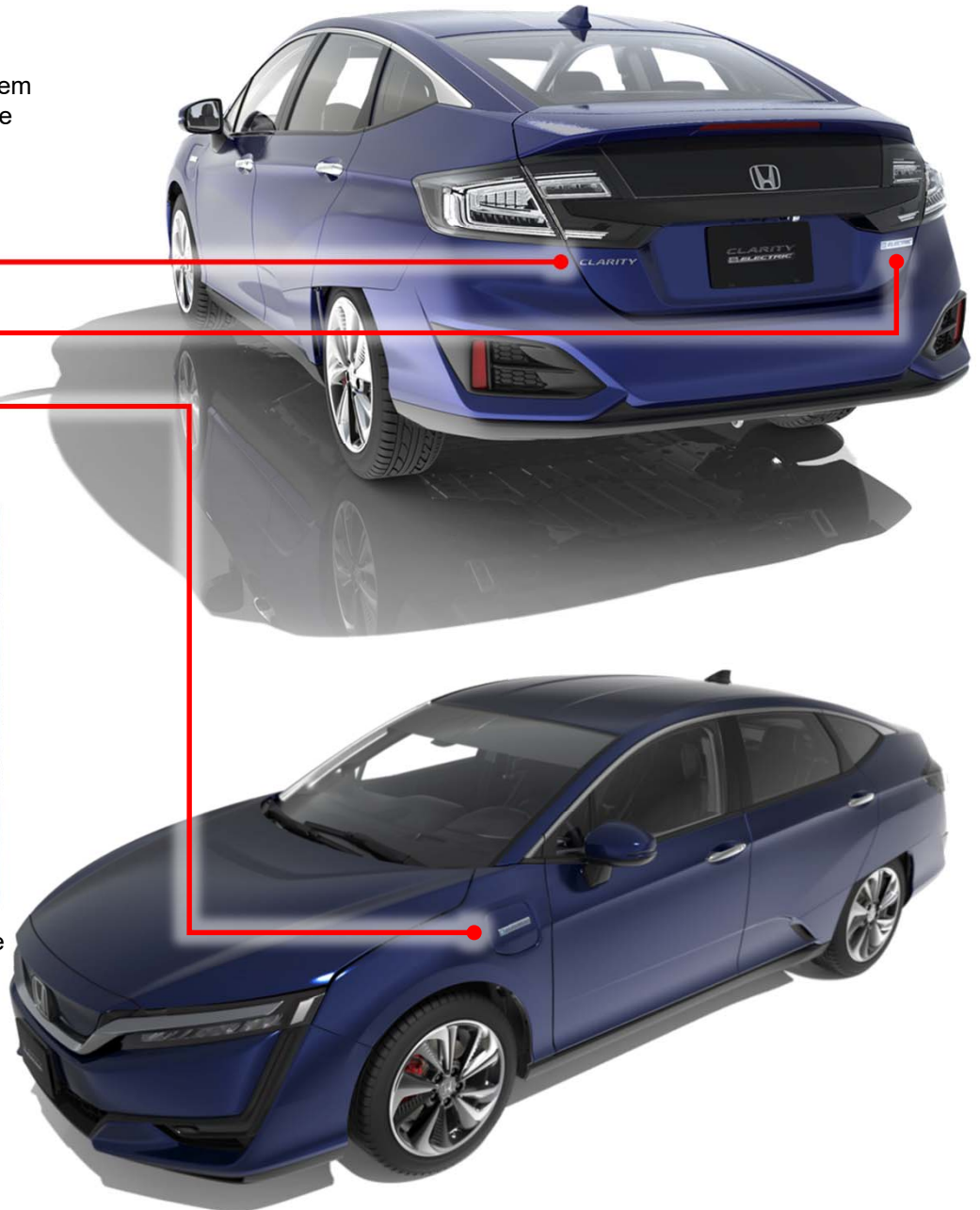



A Honda Clarity Electric can also be identified by inspecting the VIN at the three locations shown below.

The characters 4 thru 6 of the VIN will show **ZC6** indicating that it is a Honda Clarity Electric.

JHMZC6\*\*\*\*\*000001



VIN plate located on the lower-right corner of the front windshield



Stamped into the floor panel in front of the passenger seat under a plastic panel marked **FRAME NUMBER**



Printed on the VIN label on the driver's doorjamb

### Warning Labels

**WARNING**

Flammable Refrigerant  
CAUTION SYSTEM CONTAINS REFRIGERANT R-1234yf UNDER HIGH PRESSURE.  
TO BE SERVICED ONLY BY QUALIFIED PERSONNEL.  
Follow Instructions in the service manual.

**AIR CONDITIONER SYSTEM**  
REFRIGERANT : R-1234yf (SAE J639 J2842 J2845)  
REC. CHARGE : MAX 0.825kg MIN 0.775kg  
OIL TYPE : SE-A2 (POE)

TRV Honda Motor Co., Ltd.

**VEHICLE EMISSION CONTROL INFORMATION**  
CONFORMS TO REGULATIONS: 2017MY BEV

U.S. EPA: T3B0 LDV	OBD: N/A	FUEL: ELECTRIC	 <b>6-5</b> 5WP-A00
CALIFORNIA: ZEV PC	OBD: N/A	FUEL: ELECTRIC	
GROUP: HHNXV00.08E9	EVAP: N/A		HONDA MOTOR CO., LTD.

**INFORMATION**

- WHEN ADDING OR REPLACING THE COOLANT, ALWAYS USE **Honda RECOMMENDED GENUINE** LONG-LIFE ANTI-FREEZE / COOLANT TYPE 2. THIS COOLANT IS PRE-MIXED WITH 50% DISTILLED WATER. IT DOES NOT REQUIRE ANY ADDITIONAL MIXING.
- NEVER DILUTE THE COOLANT, OR THE LIFE OF THE ENGINE MAY BE SERIOUSLY SHORTENED.
- CHECK OR ADD THE COOLANT AT THE RESERVE TANK, NOT THE RADIATOR.
- FOR FURTHER INFORMATION ON THE COOLING SYSTEM, READ THE OWNER'S MANUAL OR CHECK WITH YOUR Honda DEALER.

**NOTICE**

If this vehicle is not driven for 3 months or longer, the high-voltage Lithium-ion battery can be permanently damaged due to prolonged low state of charge. To maintain the battery while the vehicle is not in use, recharge the battery at least once every three months.

**LITHIUM-ION BATTERY DISPOSAL INFORMATION**

Two large high-voltage Lithium-ion batteries are located below the seating area floor pan and cargo space. The high-voltage Lithium-ion batteries require a special disposal process. Call 1-800-555-3497 for handling and disposal information.

  
High-voltage Lithium-ion battery

5WP-A0

Model No. TRV-001  
American Honda Motor Co., Inc.

This device complies with Part 15 of the FCC Rules. Operation is subject to the following two conditions:  
(1) this device may not cause harmful interference, and  
(2) this device must accept any interference received, including interference that may cause undesired operation.

**WARNING**

**HIGH VOLTAGE**  
You can be killed or hurt. Do not disconnect, open, or take apart.

A0

**DANGER WARNING**  
危険 危険  
NEVER OPEN WHEN HOT.  
Hot coolant will scald you.  
N'OUVREZ PAS QUAND CHAUD.  
NICHT BEI HEISSEM MOTOR ÖFFNEN.  
熱い時あけないでください。  
高温時、请勿打开

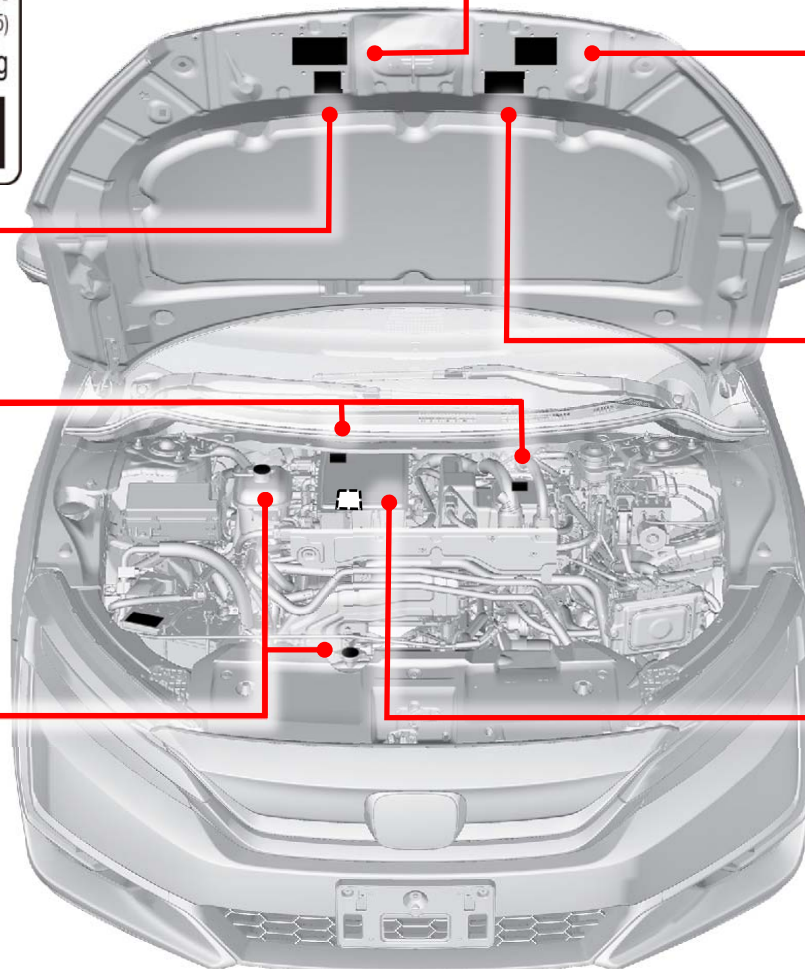

**WARNING**

**HIGH VOLTAGE**  
You can be killed or hurt. Do not disconnect, open, or take apart.

**When you remove and attach the PCU**  
When you remove and attach the PCU, conduct maintenance according to the service manual.

\*Under charge frame assembly



### Warning Labels (continued)

⚠ DANGER	⚠ PELIGRO	⚠ DANGER
 <p><b>HIGH VOLTAGE</b> You will be killed or hurt. Before servicing</p> <ul style="list-style-type: none"> <li>Switch vehicle power mode to off and remove high-voltage battery service plug.</li> <li>Wear insulated gloves and use insulated tools.</li> <li>Check voltage at high-voltage battery box terminals.</li> <li>Follow all service manual instructions.</li> </ul>	 <p><b>ALTA TENSION</b> Peligro de accidente o muerte. Antes de manipular</p> <ul style="list-style-type: none"> <li>Cambie el interruptor de encendido del vehículo a OFF y retire el conector de servicio de la batería de alta tensión.</li> <li>Utilice guantes y herramientas aislantes.</li> <li>Compruebe el voltaje en las terminales de la caja de la batería de alta tensión.</li> <li>Siga todas las instrucciones del manual de servicio.</li> </ul>	 <p><b>HAUTE TENSION</b> Danger de mort ou de blessures. Avant le service</p> <ul style="list-style-type: none"> <li>Mettez le mode d'alimentation du véhicule à OFF, puis retirez le capuchon de la prise de service de la batterie haute tension.</li> <li>Porter des gants isolants et utiliser des outils isolés.</li> <li>Vérifier la tension aux bornes du boîtier de la batterie haute tension.</li> <li>Suivez toutes les instructions du manuel d'atelier.</li> </ul>

5WP  
-A0

<p><b>LITHIUM-ION BATTERY DISPOSAL INFORMATION</b></p> <p>This high voltage battery requires a special handling and disposal process. Contact for instructions, in USA : Call 1-800-555-3497 in Canada : Call 1-888-946-6329</p>	<p><b>MISE AU REBUT DES BATTERIES LITHIUM-ION</b></p> <p>La manutention et la mise au rebut de la batterie haute tension nécessitent un processus spécial. Pour les directives, contactez : aux É.-U. : 1-800-555-3497 au Canada : 1-888-946-6329</p>
--	---

5WP-A0

⚠ DANGER	⚠ PELIGRO	⚠ DANGER
<p><b>IMPACT</b> Strong impact (i.e., dropping the battery, collision damage) may cause electrolyte leaks, internal short circuits and heat increase resulting in fire. Avoid impact to the battery.</p> <p><b>FLAMMABLE LIQUID and VAPOR</b> Battery damage may cause flammable gas or electrolyte leaks and may result in fire. Do not damage the battery and keep sparks, flame and cigarettes away.</p> <p><b>CHEMICAL HAZARD - CORROSIVE</b> Organic electrolyte may cause severe burns to skin and eyes. Wear personal protective equipment.</p> <p><b>POISON</b> Organic electrolyte is poisonous. If ingested, get medical attention immediately.</p> <p><b>KEEP OUT OF REACH OF CHILDREN</b></p>	<p><b>IMPACTO</b> Impacto fuerte (es decir, dejar caer la batería, el daño causado por la colisión) puede causar fuga de electrolitos, cortocircuitos internos y aumento de temperatura pudiendo provocar un incendio. Evite el impacto a la batería.</p> <p><b>LÍQUIDOS INFLAMABLES y VAPOR</b> Daño en la batería puede causar fuga de electrolitos o gas inflamable y puede provocar un incendio. No dañe la batería y manténgase lejos de chispas, fuego y cigarras.</p> <p><b>RIESGO QUÍMICO - CORROSIVO</b> El electrolito orgánico puede causar severas quemaduras en la piel y los ojos. Use equipo de protección personal.</p> <p><b>VENENO</b> El electrolito orgánico es venenoso. En caso de ingestión, busque atención médica inmediatamente.</p> <p><b>MANTÉNGASE FUERA DEL ALCANCE DE LOS NIÑOS</b></p>	<p><b>CHOC</b> Choc important (c'est à dire : faire tomber la batterie, les dommages par collision) peut provoquer des fuites d'électrolyte, courts-circuits internes et l'élévation de la température qui peuvent entraîner un incendie. Éviter tout choc sur la batterie.</p> <p><b>LIQUIDE et VAPEUR INFLAMMABLES</b> L'endommagement de la batterie peut provoquer des fuites de gaz ou d'électrolyte inflammables et peut entraîner un incendie. Ne pas endommager la batterie. Éloigner de toute étincelle, flamme nue ou cigarette allumée.</p> <p><b>RISQUE CHIMIQUE - CORROSIF</b> L'électrolyte organique peut causer de graves brûlures à la peau et aux yeux. Porter un équipement de protection individuelle.</p> <p><b>POISON</b> L'électrolyte organique est toxique. En cas d'ingestion, consulter immédiatement un médecin.</p> <p><b>GARDER HORS DE LA PORTÉE DES ENFANTS</b></p>
 SHIELD EYES PROTEJA LOS OJOS PROTÉGEZ LES YEUX	 NO FIRE NO FUEGO AUCUNE SOURCE DE FEU	 CORROSIVE ORGANIC ELECTROLYTE ELECTROLITO ORGÁNICO CORROSIVO ÉLECTROLYTE ORGANIQUE CORROSIF
		 GET MEDICAL HELP FAST OBTENGA AYUDA MÉDICA RÁPIDA OBTENIR RAPIDEMENT DE L'AIDE MÉDICALE
 <b>Li-ion</b>		 5WP-A0

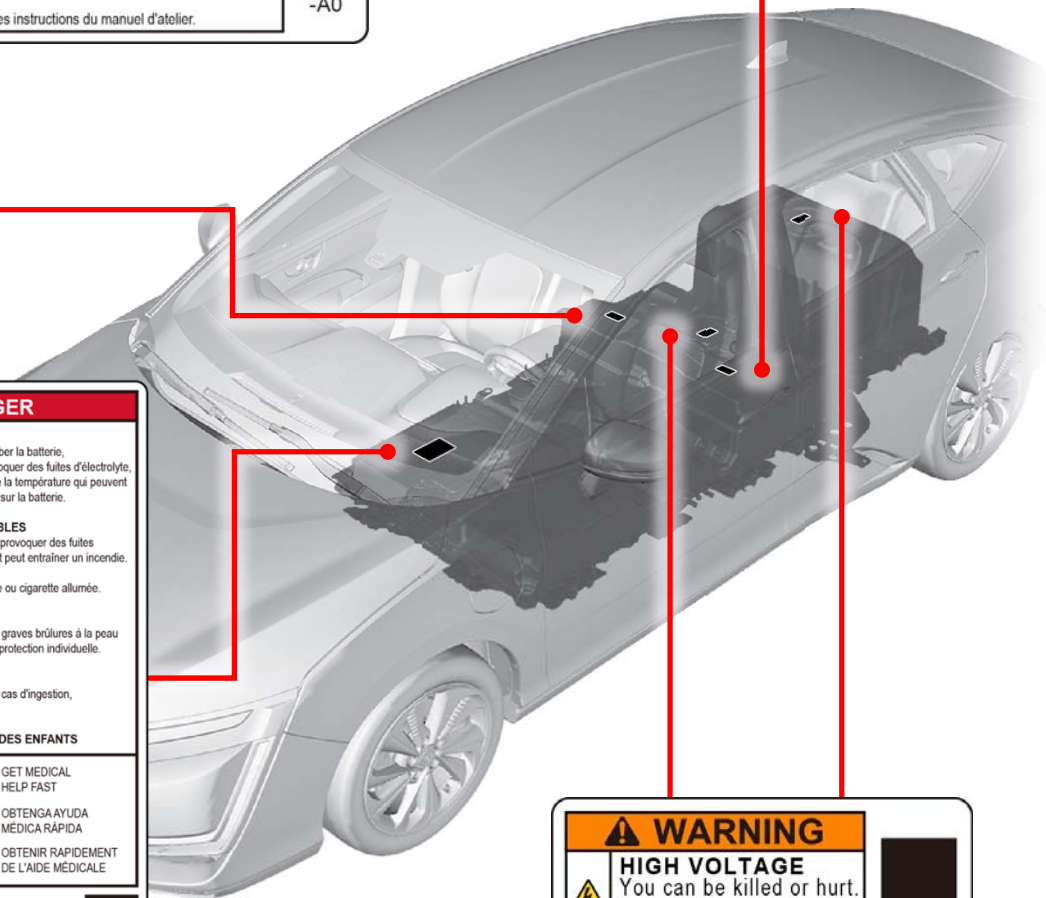

<b>⚠ WARNING</b>	
 <p><b>HIGH VOLTAGE</b> You can be killed or hurt. Do not disconnect, open, or take apart.</p>	 A0

### Warning Labels (continued)

⚠ DANGER	⚠ PELIGRO	⚠ DANGER
 <p><b>HIGH VOLTAGE</b> You will be killed or hurt. Before servicing</p> <ul style="list-style-type: none"> <li>Switch vehicle power mode to off and remove high-voltage battery service plug.</li> <li>Wear insulated gloves and use insulated tools.</li> <li>Check voltage at high-voltage battery box terminals.</li> <li>Follow all service manual instructions.</li> </ul>	 <p><b>ALTA TENSION</b> Peligro de accidente o muerte. Antes de manipular</p> <ul style="list-style-type: none"> <li>Cambie el interruptor de encendido del vehículo a OFF y retire el conector de servicio de la batería de alta tensión.</li> <li>Utilice guantes y herramientas aislantes.</li> <li>Compruebe el voltaje en las terminales de la caja de la batería de alta tensión.</li> <li>Siga todas las instrucciones del manual de servicio.</li> </ul>	 <p><b>HAUTE TENSION</b> Danger de mort ou de blessures. Avant le service</p> <ul style="list-style-type: none"> <li>Mettez le mode d'alimentation du véhicule à OFF, puis retirez le capuchon de la prise de service de la batterie haute tension.</li> <li>Porter des gants isolants et utiliser des outils isolés.</li> <li>Vérifier la tension aux bornes du boîtier de la batterie haute tension.</li> <li>Suivez toutes les instructions du manuel d'atelier.</li> </ul>

5WP  
-A0

<p><b>LITHIUM-ION BATTERY DISPOSAL INFORMATION</b></p> <p>This high voltage battery requires a special handling and disposal process. Contact for instructions, in USA : Call 1-800-555-3497 in Canada : Call 1-888-946-6329</p>	<p><b>MISE AU REBUT DES BATTERIES LITHIUM-ION</b></p> <p>La manutention et la mise au rebut de la batterie haute tension nécessitent un processus spécial. Pour les directives, contactez : aux É.-U. : 1-800-555-3497 au Canada : 1-888-946-6329</p>
--	---

5WP-A0

⚠ DANGER	⚠ PELIGRO	⚠ DANGER
<p><b>IMPACT</b> Strong impact (i.e., dropping the battery, collision damage) may cause electrolyte leaks, internal short circuits and heat increase resulting in fire. Avoid impact to the battery.</p> <p><b>FLAMMABLE LIQUID and VAPOR</b> Battery damage may cause flammable gas or electrolyte leaks and may result in fire. Do not damage the battery and keep sparks, flame and cigarettes away.</p> <p><b>CHEMICAL HAZARD - CORROSIVE</b> Organic electrolyte may cause severe burns to skin and eyes. Wear personal protective equipment.</p> <p><b>POISON</b> Organic electrolyte is poisonous. If ingested, get medical attention immediately.</p> <p><b>KEEP OUT OF REACH OF CHILDREN</b></p>	<p><b>IMPACTO</b> Impacto fuerte (es decir, dejar caer la batería, el daño causado por la colisión) puede causar fuga de electrolitos, cortocircuitos internos y aumento de temperatura pudiendo provocar un incendio. Evite el impacto a la batería.</p> <p><b>LÍQUIDOS INFLAMABLES y VAPOR</b> Daño en la batería puede causar fuga de electrolitos o gas inflamable y puede provocar un incendio. No dañe la batería y manténgase lejos de chispas, fuego y cigarras.</p> <p><b>RIESGO QUÍMICO - CORROSIVO</b> El electrolito orgánico puede causar severas quemaduras en la piel y los ojos. Use equipo de protección personal.</p> <p><b>VENENO</b> El electrolito orgánico es venenoso. En caso de ingestión, busque atención médica inmediatamente.</p> <p><b>MANTÉNGASE FUERA DEL ALCANCE DE LOS NIÑOS</b></p>	<p><b>CHOC</b> Choc important (c'est à dire : faire tomber la batterie, les dommages par collision) peut provoquer des fuites d'électrolyte, courts-circuits internes et l'élévation de la température qui peuvent entraîner un incendie. Éviter tout choc sur la batterie.</p> <p><b>LIQUIDE et VAPEUR INFLAMMABLES</b> L'endommagement de la batterie peut provoquer des fuites de gaz ou d'électrolyte inflammables et peut entraîner un incendie. Ne pas endommager la batterie. Éloigner de toute étincelle, flamme nue ou cigarette allumée.</p> <p><b>RISQUE CHIMIQUE - CORROSIF</b> L'électrolyte organique peut causer de graves brûlures à la peau et aux yeux. Porter un équipement de protection individuelle.</p> <p><b>POISON</b> L'électrolyte organique est toxique. En cas d'ingestion, consultez immédiatement un médecin.</p> <p><b>GARDER HORS DE LA PORTÉE DES ENFANTS</b></p>
 SHIELD EYES PROTEJA LOS OJOS PROTÉGEZ LES YEUX	 NO FIRE NO FUEGO AUCUNE SOURCE DE FEU	 CORROSIVE ORGANIC ELECTROLYTE ELECTROLITO ORGÁNICO CORROSIVO ÉLECTROLYTE ORGANIQUE CORROSIF
		 GET MEDICAL HELP FAST OBTENGA AYUDA MÉDICA RÁPIDA OBTENIR RAPIDEMENT DE L'AIDE MÉDICALE
 <b>Li-ion</b>		 5WP-A0

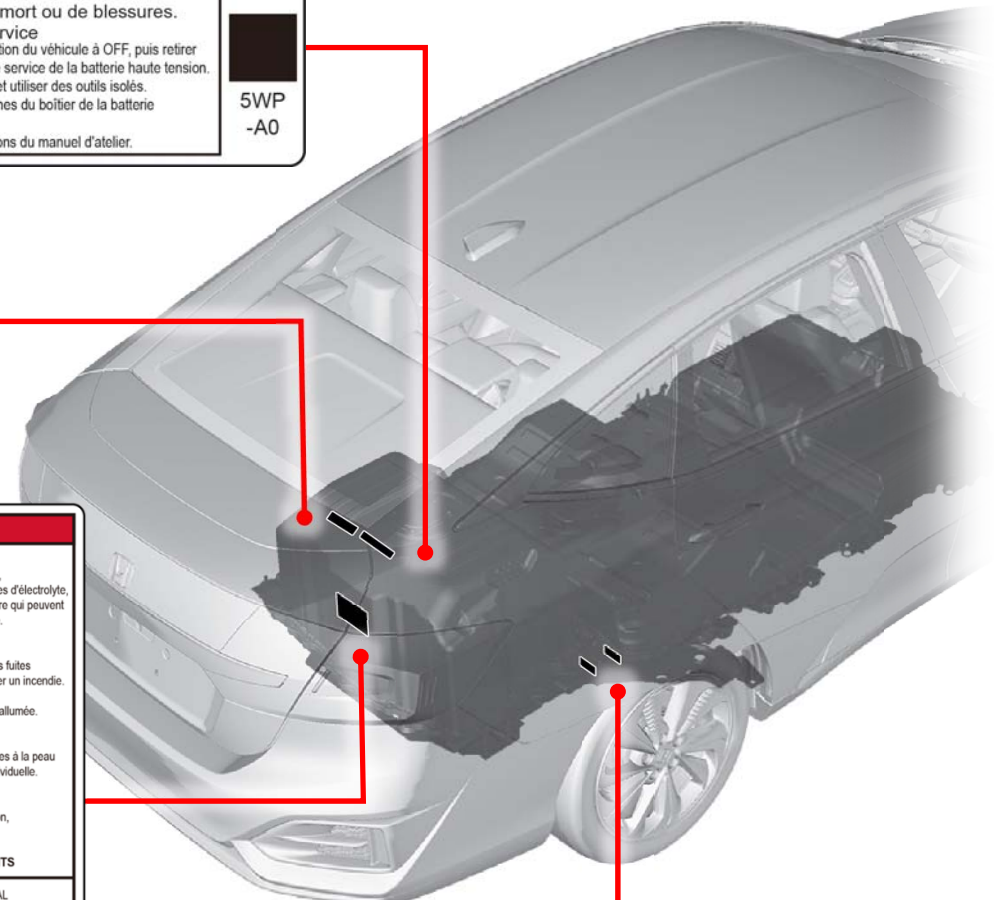

<b>⚠ WARNING</b>	
 <p><b>HIGH VOLTAGE</b> You can be killed or hurt. Do not disconnect, open, or take apart.</p>	<b>A0</b>



### High-Voltage Battery - Location

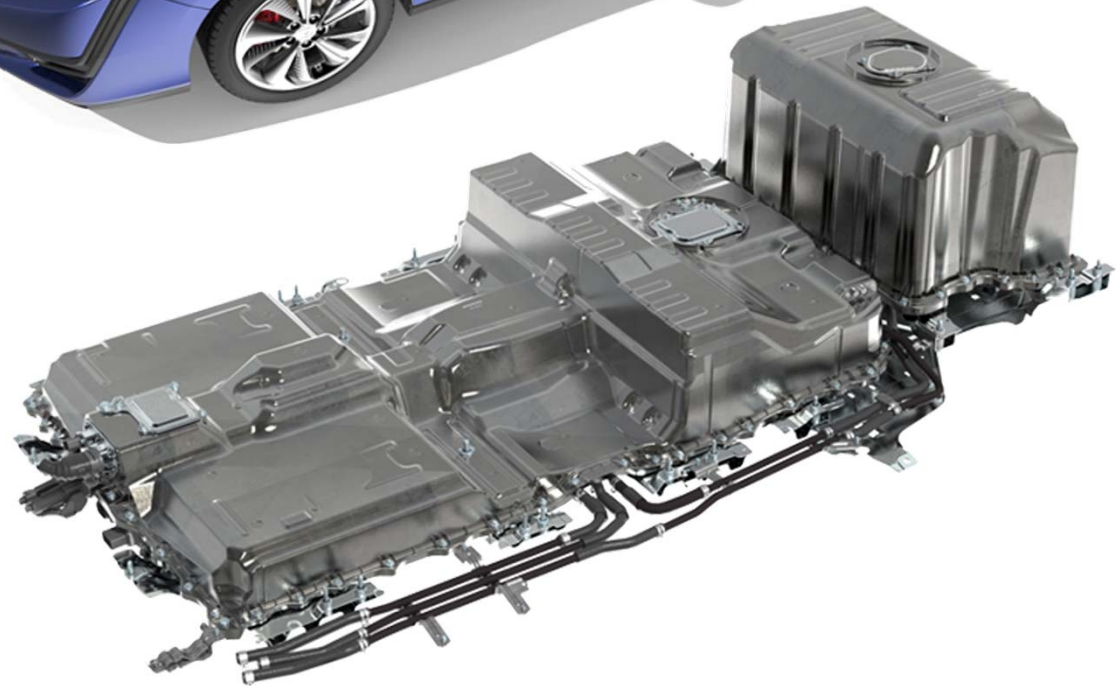
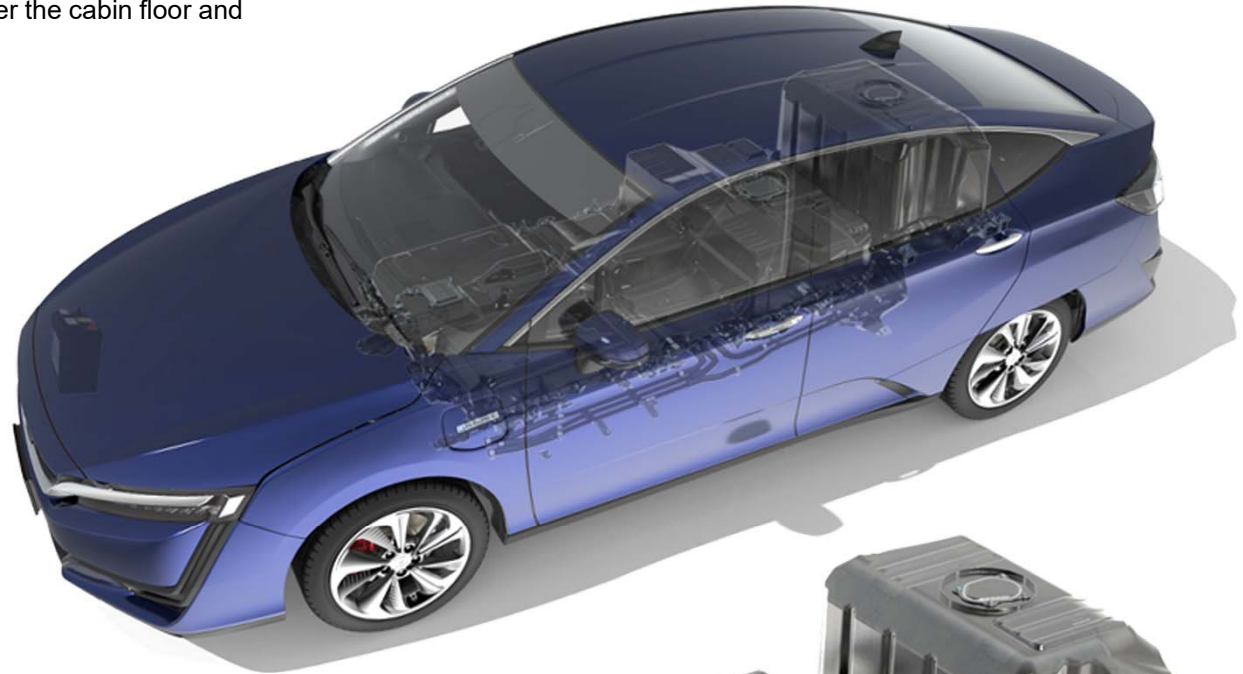
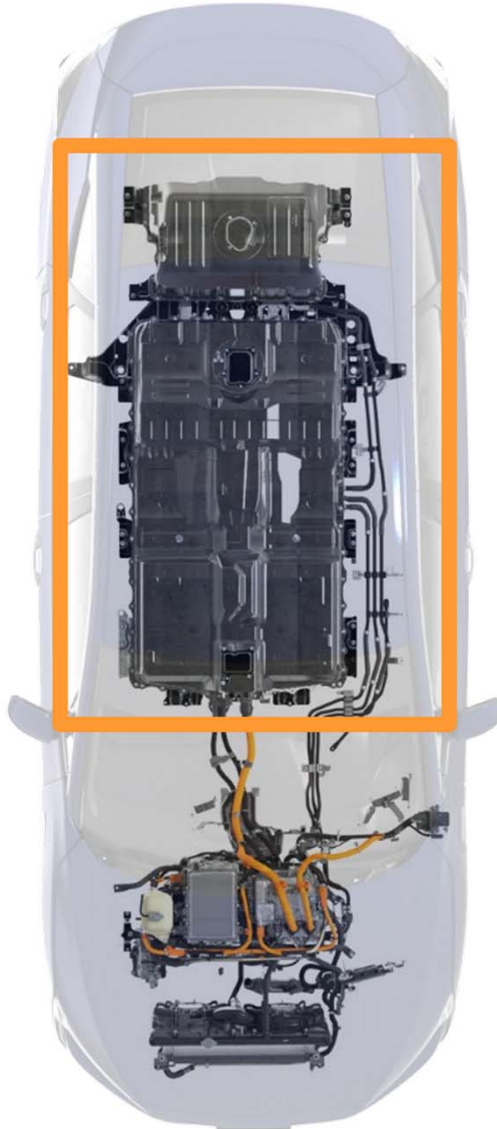

The two high-voltage batteries are located under the cabin floor and under the rear section of the body.





### How to Determine if Vehicle is in ON / OFF Mode.

Check the illumination of the POWER button for the vehicle status.

<p><b>Vehicle is OFF</b> The power to all electrical components is turned off.</p> <ul style="list-style-type: none"> <li>• The POWER button and the green indicator are OFF.</li> <li>• Pressing the POWER button once will change to the Accessory mode.</li> </ul>	 <p>OFF</p>
<p><b>Vehicle is in Accessory</b> You can operate the audio system and other accessories in this position.</p> <ul style="list-style-type: none"> <li>• The POWER button is blinking.</li> <li>• Press the POWER button twice to turn off the vehicle.</li> <li>• Pressing the POWER button once will change to the ON mode.</li> </ul>	 <p>BLINK</p>
<p><b>Vehicle is ON</b> The Engine is OFF but all electrical components can be used.</p> <ul style="list-style-type: none"> <li>• The POWER button is ON.</li> <li>• Press the POWER button once to turn off the vehicle.</li> <li>• While pressing the brake pedal, pressing the POWER button once will change to the Ready to Drive mode.</li> </ul>	 <p>ON</p>

**Vehicle is Ready to Drive**  
Ready To Drive is shown on the Multi-Information Display (MID).

- The POWER button is ON.
- The **READY** indicator is ON.
- The **EV** indicator is ON.
- Press the POWER button once to turn OFF the vehicle.



ON



### Parking the Vehicle

#### NOTE:

- The following features will only operate if the vehicle's 12-volt battery power is available.
- If the 12-volt power IS NOT available, use available wheel chocks.

1. Press the POWER button twice to turn the vehicle ON.
2. Press the P on the Electronic Gear Selector to shift the transmission to Park.
3. Push the POWER button to turn the vehicle OFF.
4. If necessary, pull up the Electric Parking Brake switch to apply the parking brake.

#### Applying the Electric Parking Brake

The electric parking brake can be applied any time the vehicle has battery power no matter what state the power mode is in.

Pull up the Electric Parking Brake switch gently and securely.

The parking brake and Brake System indicator come on.

#### Releasing the Electric Parking Brake

The power mode must be turned to ON to release the electric parking brake.

1. Press and hold the brake pedal.
2. Press the Electric Parking Brake switch.

The parking brake and Brake System indicator go off.



### Securing the Vehicle

The recommended tie-down locations for securing the vehicle are indicated below.

- Four tie-down slots (covered by rubber plugs) - Two behind the front wheels and two in front of the rear wheels
- Front tow hook - In front of the right-front tire
- Rear tow hook – Under the center of the rear bumper

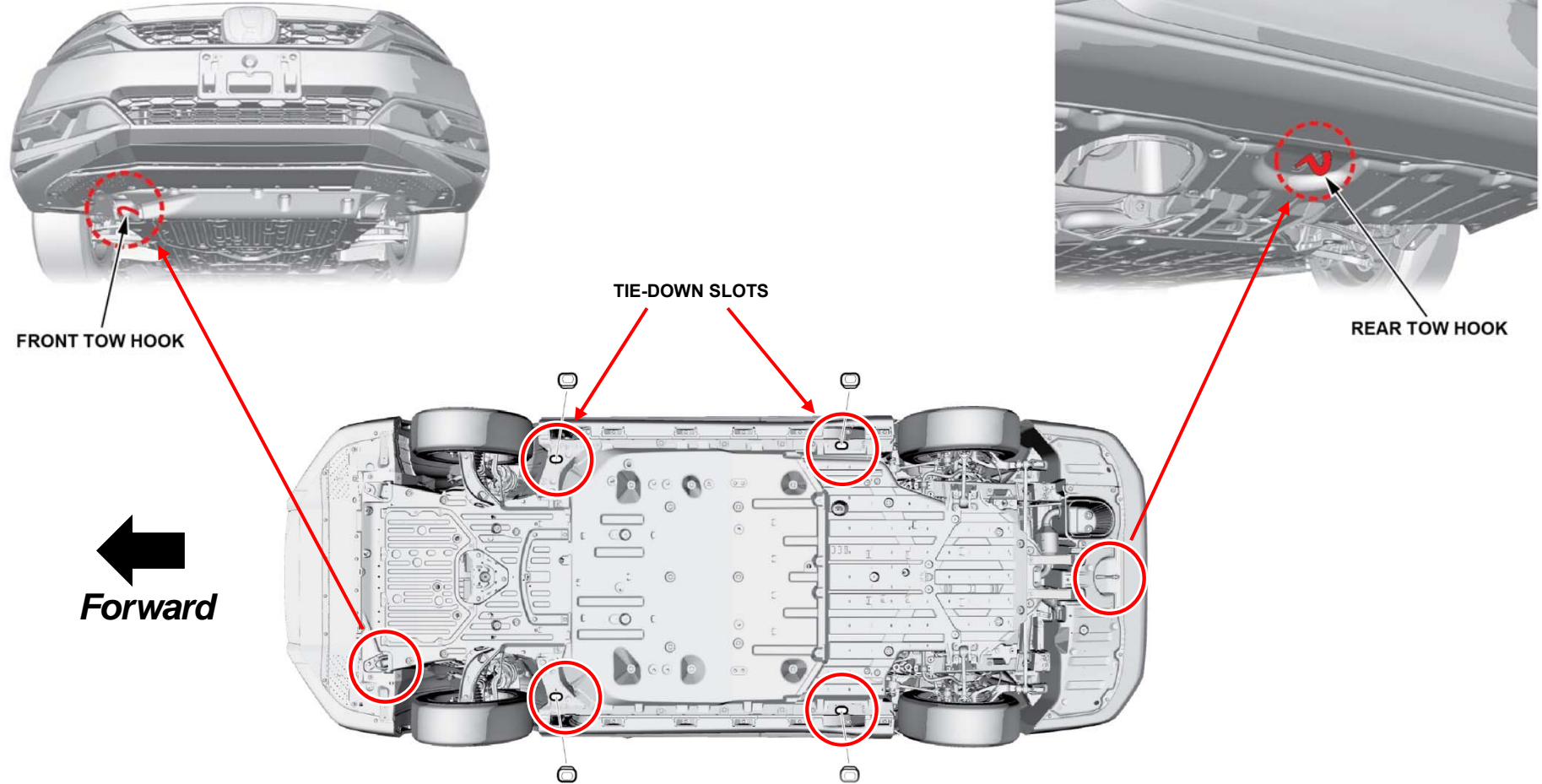

NOTE: Install the rubber plugs after use.



### Preventing Current Flow Through High-Voltage Cables

Before attempting to rescue occupants or move a damaged Honda Clarity Electric, you should reduce the potential for current to flow from the electric motor or the high-voltage battery through the high-voltage cables.

There are **two recommended methods** for preventing current flow. These are discussed on the following pages.

### PREFERRED METHOD for High-Voltage Shutdown

**Push and hold the POWER button for 3 seconds.**

This simple action turns off the vehicle and immediately shuts down the high-voltage system controllers, thereby preventing current flow into the cables. It also cuts power to the airbags and the front seat belt tensioners, though these pyrotechnic devices have up to a **3-minute** deactivation time.



To prevent accidental restarting, you must remove the keyless remote from the vehicle and move it at least **20 feet** away.



If you cannot locate the keyless remote, disconnect the negative terminal from the 12V battery to prevent electrical fires and accidental restarting of the vehicle.



### ALTERNATIVE BEST METHOD for High-Voltage Shutdown

**Locate and cut the negative 12-volt battery cable and the power control unit (PCU) cable in the engine compartment.**

Together, cutting the negative 12-volt battery cable and the PCU cable immediately turns off and shuts down the high-voltage system controllers and the engine, thereby preventing current flow to the high-voltage cables.

1. Pull the hood release handle under the driver's side lower corner of the dashboard. The hood will pop up slightly.

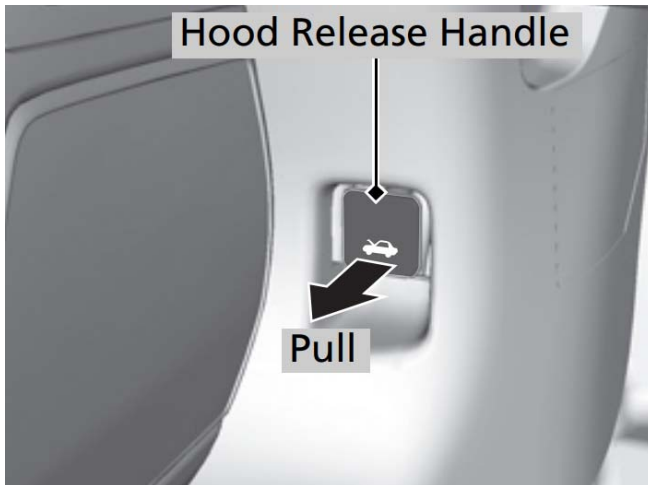

2. Push the hood latch lever (located under the front edge of the hood to the center) to the side, and raise the hood.

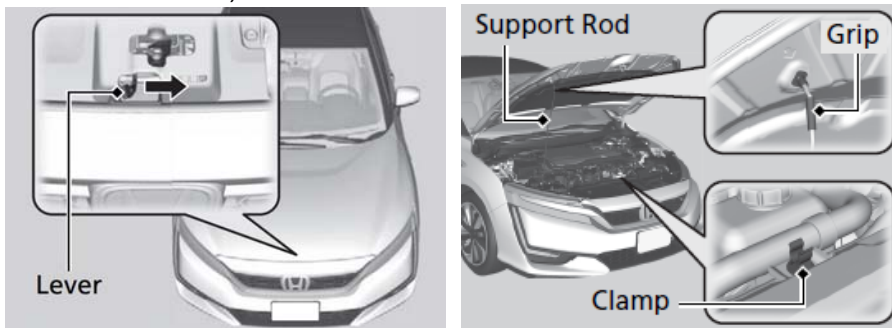

*Continued on the next page.*

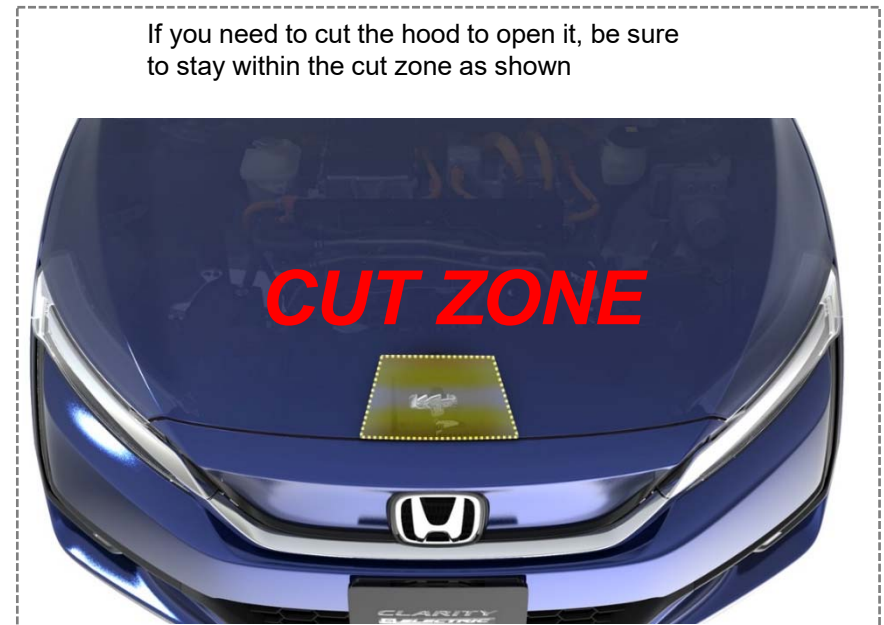



### ALTERNATIVE BEST METHOD for High-Voltage Shutdown (continued)

3. Locate the two cut point labels as shown, and cut them.

***If touching high-voltage cables and other high-voltage components is unavoidable, personal protective equipment (insulating gloves, goggles, and boots) should always be worn.***

This also cuts power to the airbags and the front seat belt tensioners, though these pyrotechnic devices have up to a **3-minute** deactivation time.

**NOTE:**

When cutting the cables, do not allow the cutting tool to contact any surrounding metal parts; electrical arcing could occur, which can ignite any flammable vapors.

If you cannot do either method to stop the engine and prevent current flow into the high-voltage cables, use extreme care and do not touch damaged cables as they may be electrically charged.

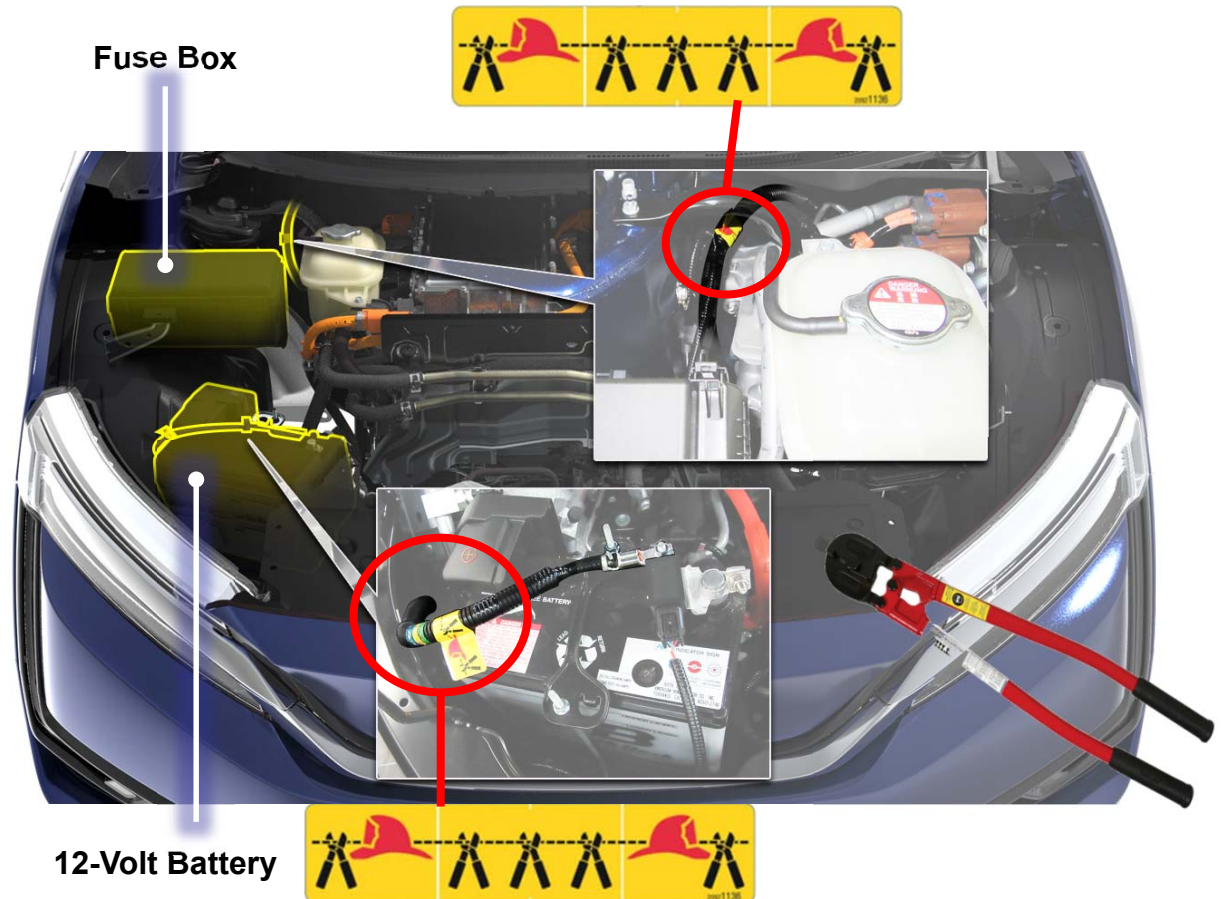

### High-Strength and Ultra-High-Strength Steel

The body of the Honda Clarity Electric is made of high-strength steel and ultra-high-strength steel indicated in the colored areas.

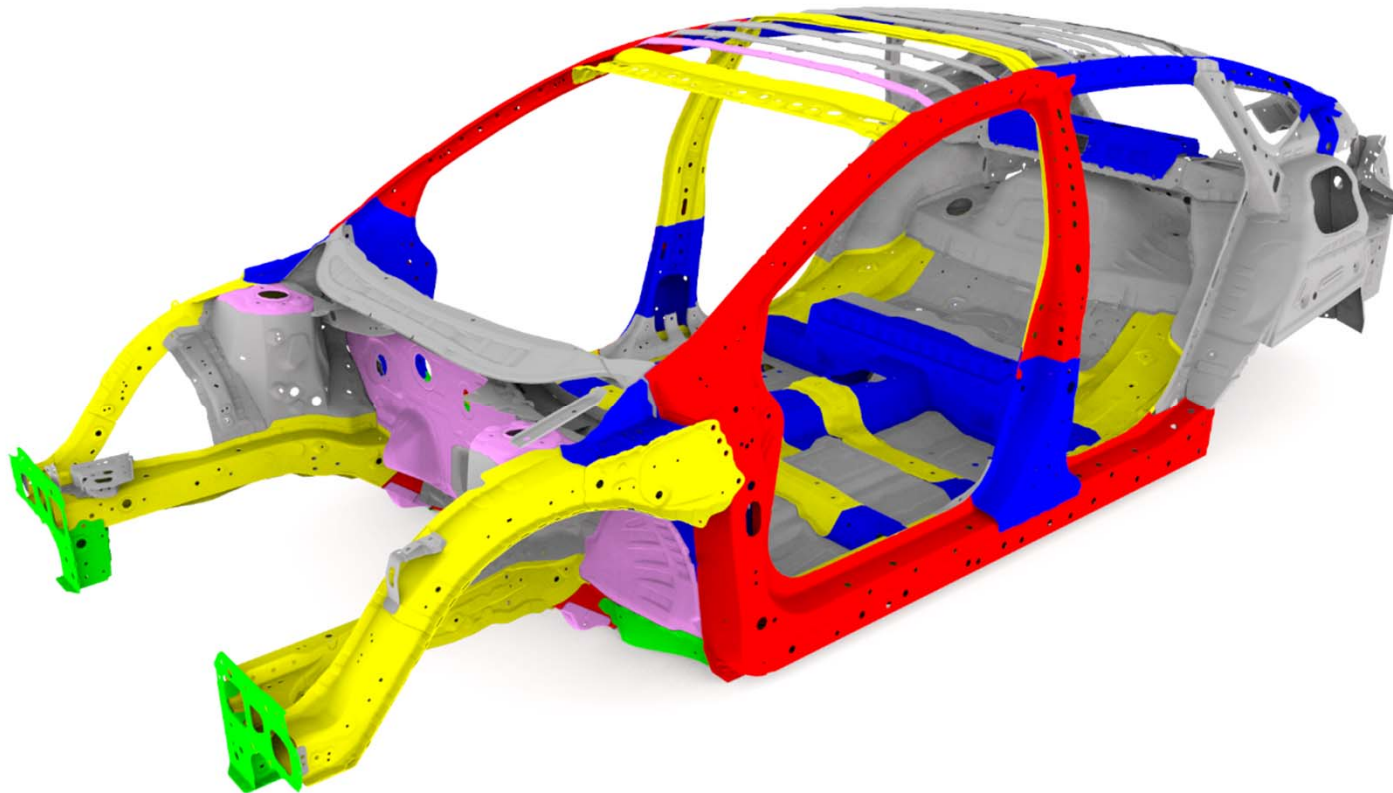

Ultra High-Strength Steel (UHSS)

High-Strength Steel (HSS)

**1500**  
Mpa

**980**  
Mpa

**780**  
Mpa

**590**  
Mpa

**440**  
Mpa

**270**  
Mpa

### High-Strength and Ultra-High-Strength Steel

The body of the Honda Clarity Electric is made of high-strength steel and ultra-high-strength steel indicated in the colored areas.

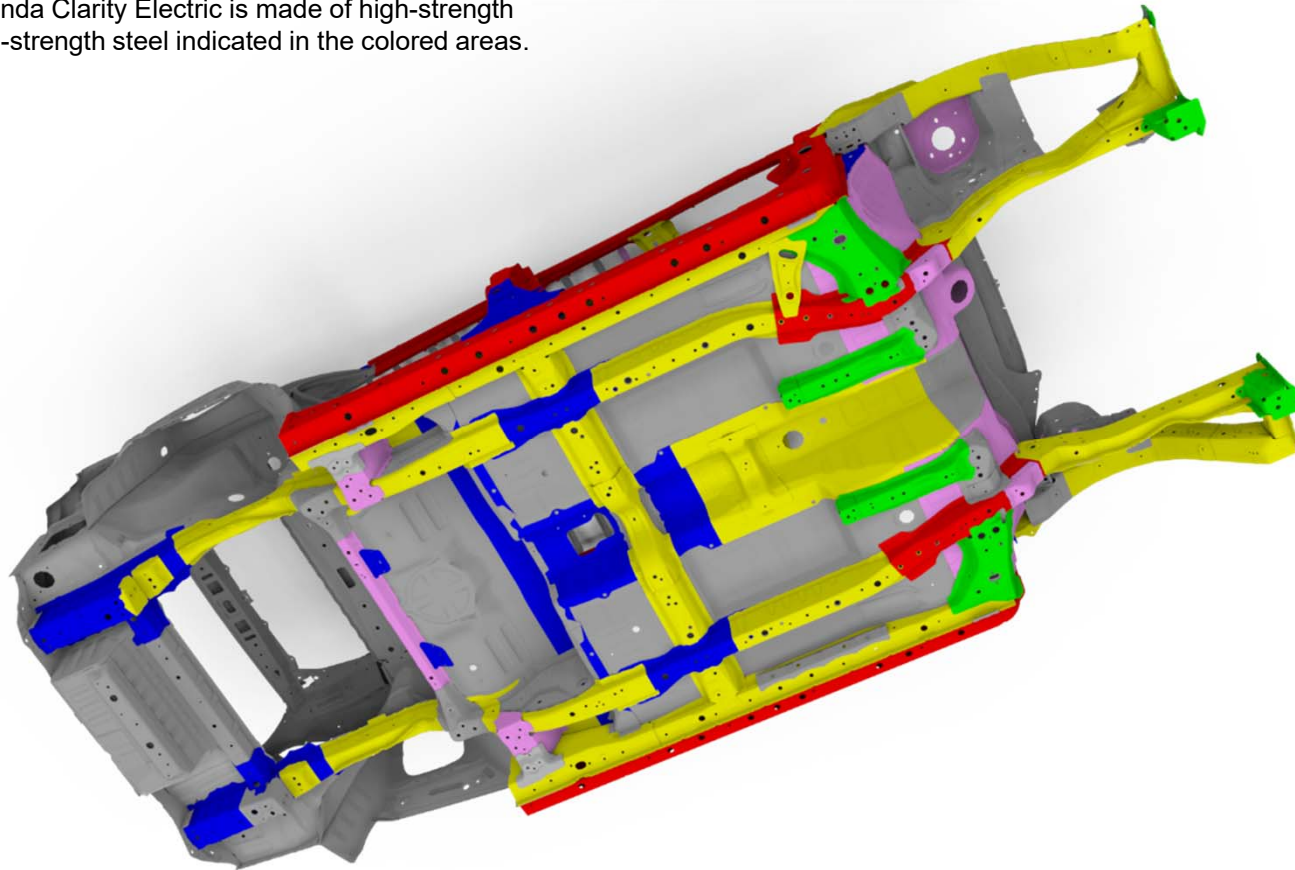

Ultra High-Strength Steel (UHSS)

High-Strength Steel (HSS)

**1500**  
Mpa

**980**  
Mpa

**780**  
Mpa

**590**  
Mpa

**440**  
Mpa

**270**  
Mpa



### Aluminum Body Parts

The indicated body parts are constructed from aluminum alloy.

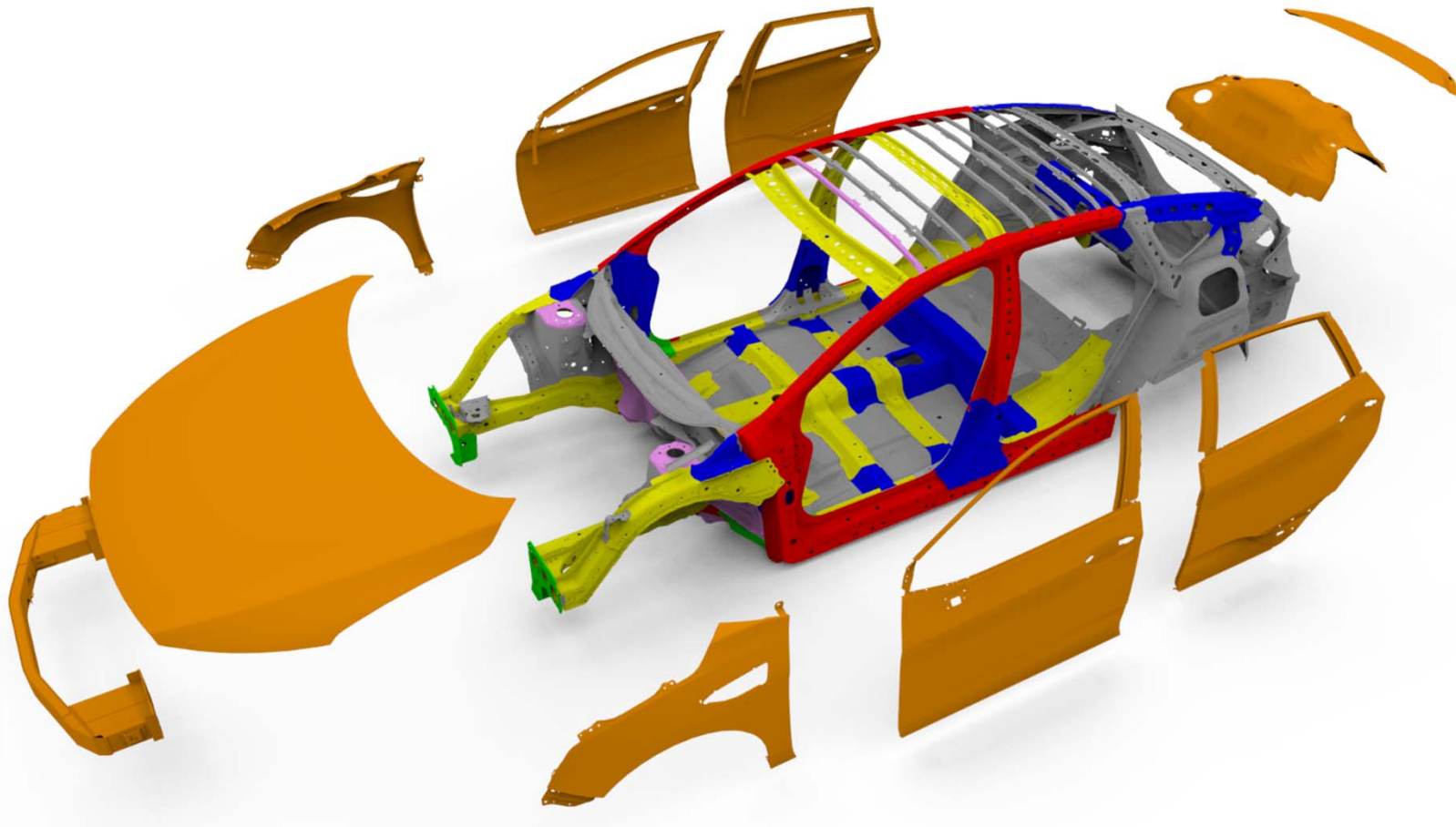

If you need to cut the vehicle body or use Jaws-of-Life equipment to remove occupants, be sure to stay within the cut zone as shown.



Side Curtain Airbag Inflator

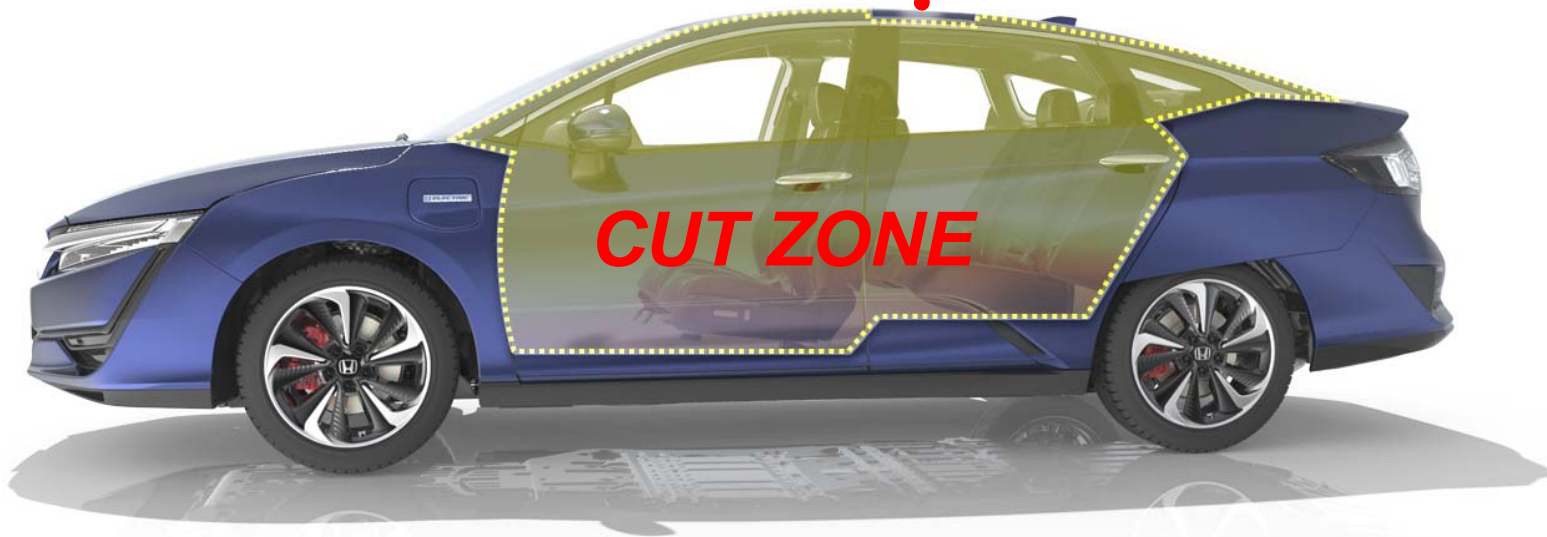



### Moving the Seats, Head Restraints & Steering Wheel

#### With Power Seats

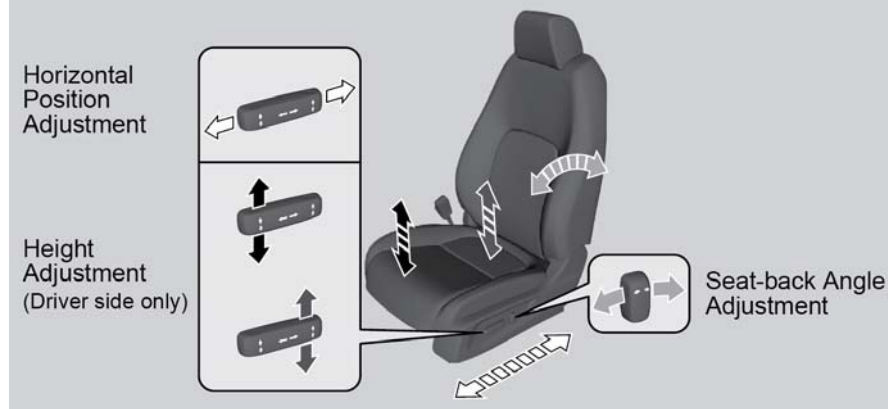

#### With Manual Seats

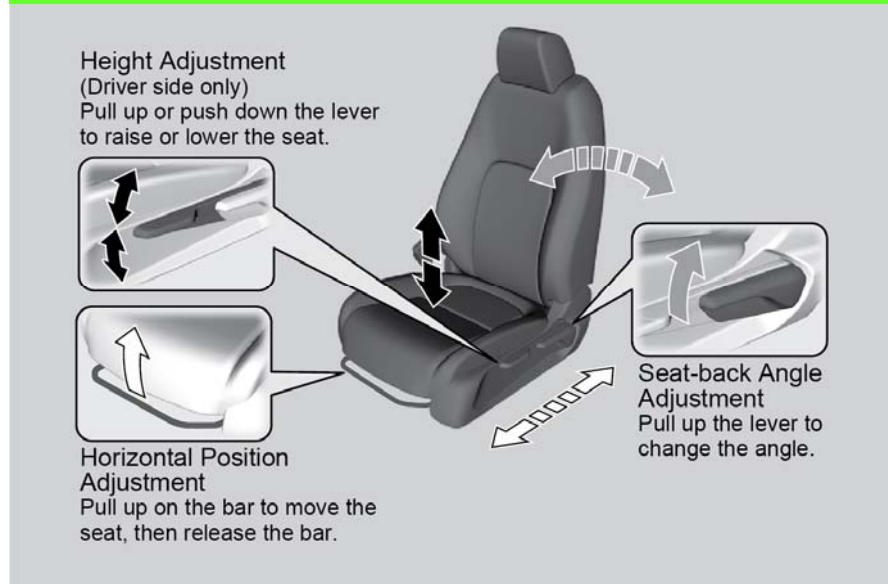

To raise the head restraint: Pull upward.



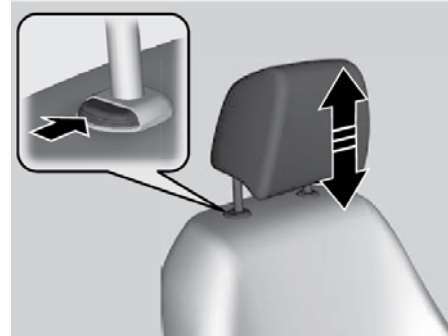



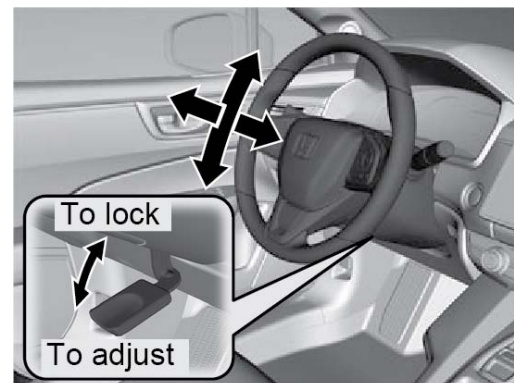

To lower the head restraint: Push down while pressing the release button.

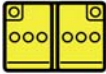





To adjust the steering wheel position:

1. Push forward on the steering wheel adjustment lever. The steering wheel adjustment lever is under the steering column.
2. Move the steering wheel up or down, and in or out.
3. Pull back on the steering wheel adjustment lever to lock the steering wheel in position.



Type	Capacity	Content	Dangers
12-Volt Battery 	12 V—36 Ah/5 HR (12 V—45 Ah/20 HR)	<ul style="list-style-type: none"> <li>• <b>Sulfuric acid</b> 34%</li> <li>• <b>Lead</b> 34%</li> <li>• <b>Lead peroxide</b> 31%</li> <li>• <b>Lead sulfate</b> 1%</li> </ul>	 
Lithium-Ion, High-Voltage Battery 	311 V 84 cells (3.7 V) (21 cells × 4 modules)	<ul style="list-style-type: none"> <li>• <b>Lithium metal oxide</b> 20-30%</li> <li>• <b>Aluminum</b> 15-25%</li> <li>• <b>Organic electrolyte</b> 15-25%</li> <li>• <b>Graphite</b> 10-20%</li> <li>• <b>Copper</b> 10-20%</li> </ul>	 
Energy Storage (ES) High-Voltage Battery Coolant	2.34 US gal (8.85 L)	<ul style="list-style-type: none"> <li>• <b>Water</b> 45-55%</li> <li>• <b>Ethylene glycol</b> 43-49 %</li> <li>• <b>Hydrated inorganic acid, organic acid salts</b> Less than 5%</li> <li>• <b>Diethylene glycol</b> less than 3%</li> </ul>	
Drivetrain (DT) Coolant	1.08 US gal (4.1 L)		
Transmission Fluid	2.01 US qt (1.9 L)	<ul style="list-style-type: none"> <li>• <b>Lubricating base stocks</b> 80-90%</li> <li>• <b>N-Phenyl-1-naphthylamine</b> less than 1%</li> </ul>	 

Type	Capacity	Content	Dangers
Brake Fluid	N/A	<ul style="list-style-type: none"> <li>• <b>Mixture of glycol ether, glycol derivative, glycol ether borate ester (except diethylene glycol) 89-99 %</b></li> <li>• <b>Diethylene glycol</b> less than 10%</li> </ul>	Not provided on SDS
Air Conditioning Refrigerant 	27.34 – 29.1 oz (775 – 825 g)	<ul style="list-style-type: none"> <li>• <b>Tetrafluoroprop-1-ene (R-1234yf) 100%</b></li> </ul>	 
Windshield Washer Fluid	1.43 US qt (1.35 L)	<b>Concentrate:</b> <ul style="list-style-type: none"> <li>• <b>Methyl Alcohol (methanol)</b> more than 99%</li> </ul> <b>Tablet:</b> <ul style="list-style-type: none"> <li>• <b>Sodium carbonate (2:1)</b> 40 to 55%</li> <li>• <b>Citric acid</b> 20 to 40%</li> <li>• <b>Ethoxylated fatty alcohols</b> 0.1 to 3%</li> <li>• <b>Alkoxyated alcohols</b> 0.1 to 2%</li> </ul>	

### Fire Extinguishing Methods

In case of vehicle high-voltage battery fire, the fire should be extinguished using the following procedure where possible.

***If touching high-voltage cables and other high-voltage components is unavoidable, personal protective equipment (insulating gloves, goggles, and boots) should always be worn.***

1. Extinguish the fire using a large volume of water such as from a fire hydrant, well water, or pond water. If water is not available, ABC powder fire extinguisher may be used as an alternative.
2. Apply water aiming **underneath** the vehicle floor from the front seat position to the rear tire position where the battery unit is located.



3. Continue extinguishing until a complete suppression of fire and smoke is observed from the battery.
4. Once signs of active fire have completely subsided (e.g. no visible smoking), a thermal camera should be used to evaluate and monitor the temperature of the battery unit.

NOTE: The battery temperature should continue to be monitored. If the battery temperature begins to increase, possibility for reignition exists and additional water or fire extinguisher should be used to mitigate reignition.

**See Section 8 (Towing/Transportation/Storage) for additional procedures including discharging the high voltage battery.**



### **Submerged Vehicle**

If a Honda Clarity Electric is submerged or partly submerged in water, first pull the vehicle out of the water, then shut down the high-voltage system. **See Section 3 (Disable Direct Hazards / Safety Regulations) for the high-voltage shutdown procedures.**

***If touching high-voltage cables and other high-voltage components is unavoidable, personal protective equipment (insulating gloves, goggles, and boots) should always be worn.***



Aside from severe damage to the vehicle, there is no risk of an electric shock from touching the vehicle's body or framework—in or out of the water. If the high-voltage battery was submerged, you may hear noises from the battery as the cells are being discharged from shorting.

**See Section 8 (Towing/Transportation/Storage) for additional procedures including discharging the high voltage battery.**





### Shifting the Vehicle into Neutral

**NOTE:**

- The following features will only operate if the vehicle's 12-volt battery power is available.
- If the 12-volt power IS NOT available, use available wheel chocks or dollies.
- See Section 2 (Immobilization/Stabilization/Lifting) for additional procedures including parking the vehicle.

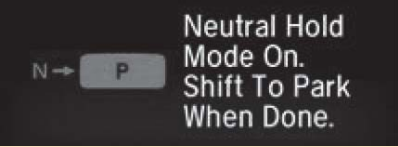
1. Press the POWER button twice to turn the vehicle ON.
2. Press and hold the brake pedal.
3. Press the N on the Electronic Gear Selector to shift the transmission to Neutral. The message, Neutral Hold will appear on the MID.
4. Press N again, and hold it for **2 seconds**. The vehicle will enter neutral hold mode.

	<ul style="list-style-type: none"> <li>• For <b>15 minutes</b>, the transmission remains in neutral and the power mode will remain in ACCESSORY. After that, the transmission automatically shifts to park.</li> </ul>
	<ul style="list-style-type: none"> <li>• If the POWER button is pressed after the neutral hold has been activated, the power mode will switch to ACCESSORY and a message will be displayed on the gauge.</li> </ul>





5. If necessary, press the Electronic Parking Brake button to release the parking brake.
6. Release the brake pedal and push the POWER button to turn the vehicle to ACCESSORY.

NOTE: Manually shifting to park cancels ACCESSORY mode. The P indicator comes on, and the power mode changes to OFF. Always shift the transmission to park when neutral hold is no longer necessary.

### Emergency Towing

The only method for emergency towing is to use a flat-bed tow truck. **DO NOT** use cable type or front wheel type lift equipment.

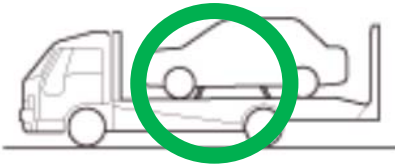
NOTE: If there is a 12-volt power failure, the vehicle cannot be shifted into neutral. Use available wheel dollies.

Flat-Bed	Front Wheel Type	Cable-type
		
<ol style="list-style-type: none"> <li>1. Secure the vehicle on the flat-bed tow truck.</li> <li>2. Apply the parking brake.</li> </ol>	<p style="text-align: center;"><b>Never tow this vehicle with front wheel type equipment.</b></p>	<p style="text-align: center;"><b>Never tow this vehicle with cable-type equipment.</b></p>

Be aware that when rolling a Honda Clarity Electric with the front (drive) wheels on the ground, the electric motor can produce electricity and remains a potential source of electric shock even when the high-voltage system is turned off.

Carry a fire extinguisher during transportation and for enhanced safety, have the flat-bed tow truck with the damaged vehicle followed by another support vehicle for monitoring. After transportation, discharge the battery if necessary. See Battery Discharging in this section.

### ⚠ WARNING

If the orange high-voltage cables or high-voltage covers have been damaged, exposing wiring, terminals, or other components, the exposed parts should never be touched. Doing so could result in serious injury or death due to severe burns or electric shock.

If it is not clear whether the exposed wires and terminals are high-voltage components or not, do not touch them.

**If touching high-voltage cables and other high-voltage components is unavoidable, personal insulating protective equipment (insulating gloves, protective goggles, and insulating boots) should always be worn.**

#### Acoustic Vehicle Alerting System

The Honda Clarity Electric is equipped with an acoustic vehicle alerting system that alerts pedestrians with an audible sound that it is approaching at low speeds or when stationary and in a gear position that would allow the vehicle to move. When pushing the Honda Clarity Electric with the ignition turned to ON, you will hear this sound as the vehicle is being moved.



### Lifting the Vehicle

Use the indicated lifting points to raise the vehicle.

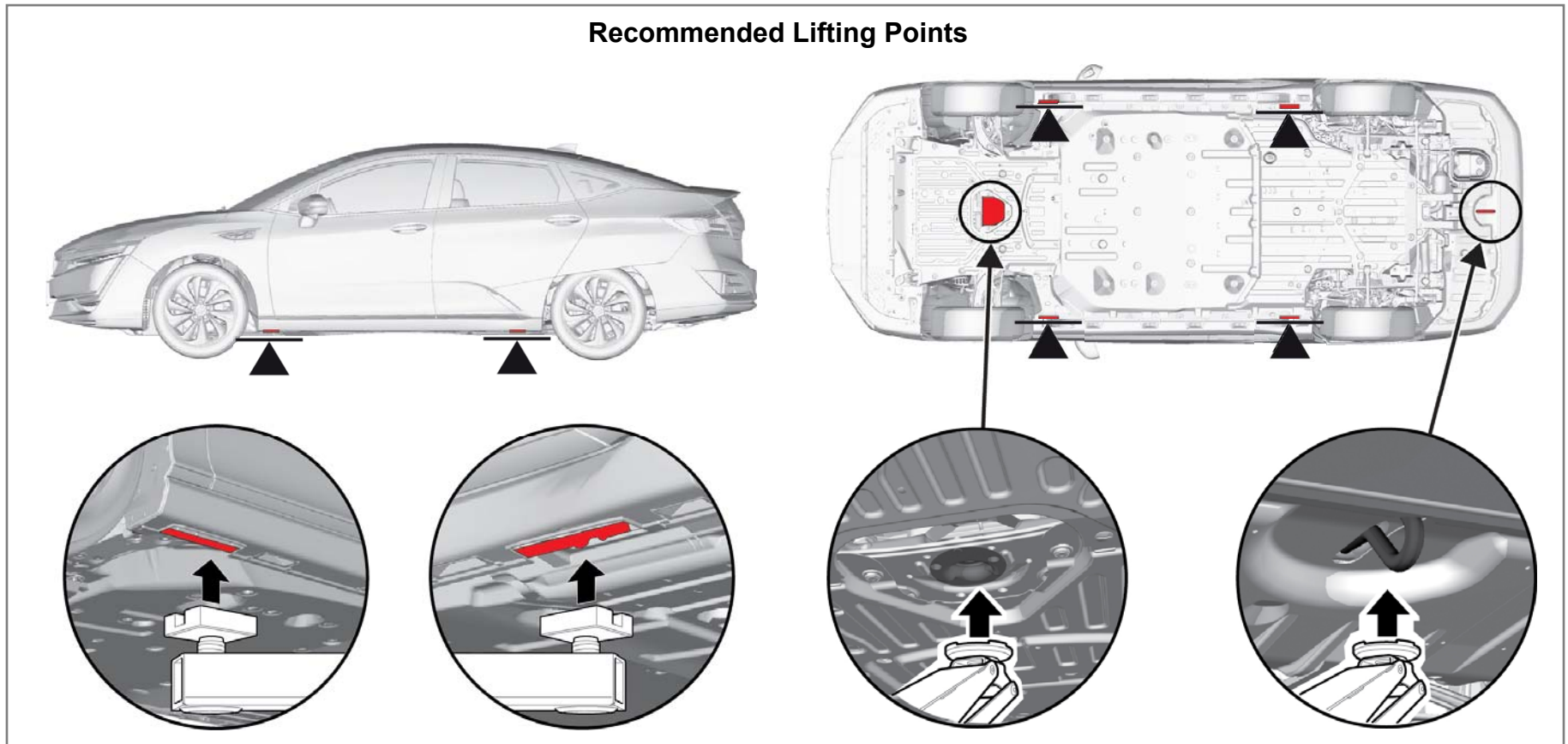

### Securing the Vehicle

The recommended tie-down locations for securing the vehicle are indicated below.

- Four tie-down slots (covered by rubber plugs) - Two behind the front wheels and two in front of the rear wheels
- Front tow hook - In front of the right-front tire
- Rear tow hook – Under the center of the rear bumper

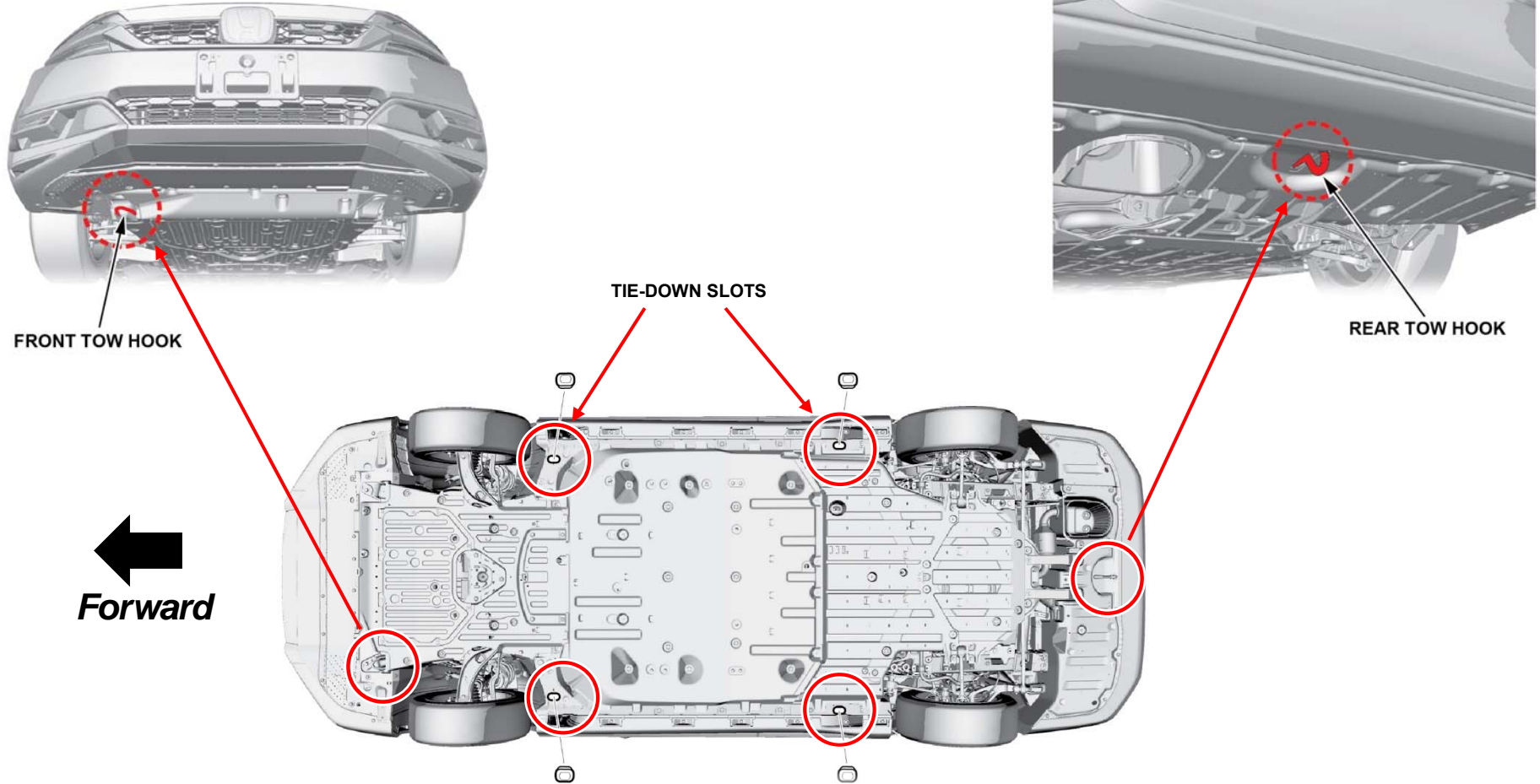

NOTE: Install the rubber plugs after use.

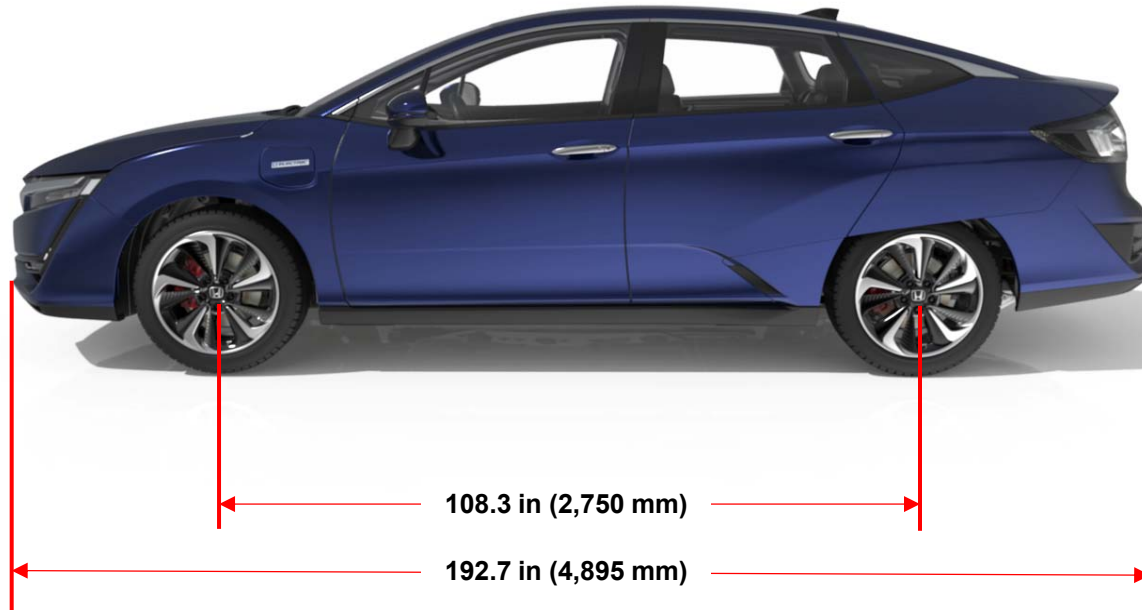

Curb Weight Rating
4,024 lbs (1,826 kg)



### Storing the Vehicle

Storage and isolation recommendations.

#### 1. Open Perimeter Isolation:

- Store the vehicle in an outdoor area separated from all combustibles and structures by a minimum distance of **50 feet (15.2 m)** from all sides.

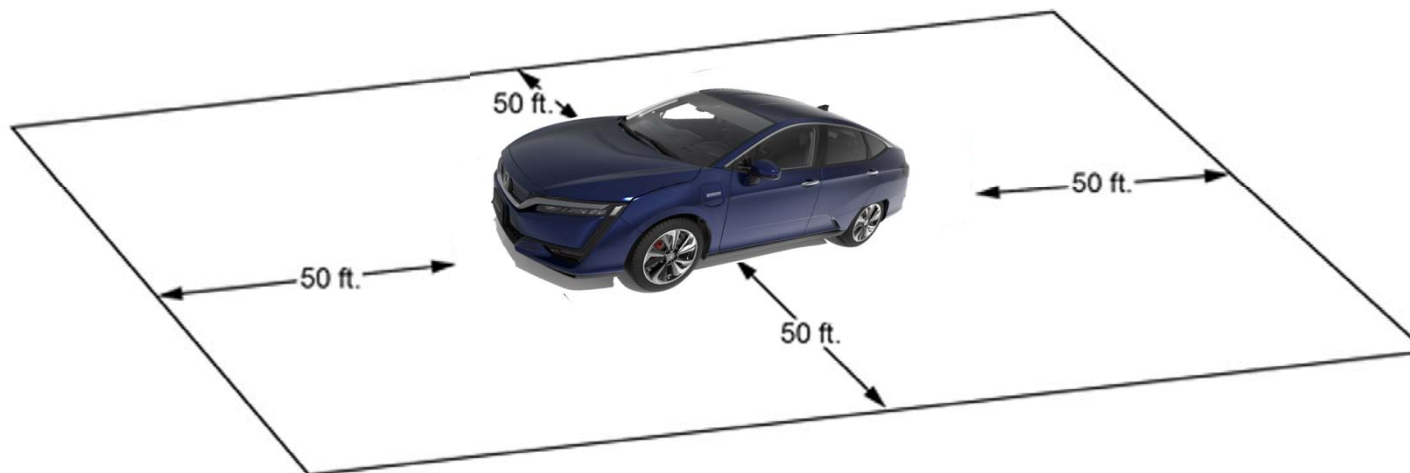

#### 2. Barrier Isolation:

- Store the vehicle in an outdoor area separated from all combustibles and structures with a barrier constructed of earth, steel, concrete or solid masonry designed to contain a fire or prevent the fire from extending to adjacent vehicles.
- Barriers should be of sufficient height to direct any flame or heat away from adjacent vehicles.
- If the barrier is provided only on three of the four sides of the vehicle, the open side must maintain the separation distance referenced in Open Perimeter Isolation.
- It is not recommended to fully enclose the vehicle in a structure due to the risk of post-incident fire extending to the structure and the possibility of trapped explosive or harmful gases. Therefore, a roof is not recommended for barrier isolation.

### Battery Discharging

If the high-voltage battery is severely damaged **or burned**, the battery must be discharged. Failure to discharge stored or stranded energy remaining in the battery may result in a fire or re-ignition due to a damaged or short circuit.

See Section 3 (Disable Direct Hazards / Safety Regulations) for procedures including disconnecting the 12-volt battery.

*If touching high-voltage cables and other high-voltage components is unavoidable, personal protective equipment (insulating gloves, goggles, and boots) should always be worn.*

1. Open the windows or doors as there is as risk of hydrogen gas filling the interior.
2. Disconnect the 12-volt battery.
3. To access the front intelligent power unit (IPU), remove the rear seat cushion.
4. Remove the service plug hole cap.
5. Remove the service plug cover 10 mm bolts, then remove the service plug cover.

*Continued on the next page.*

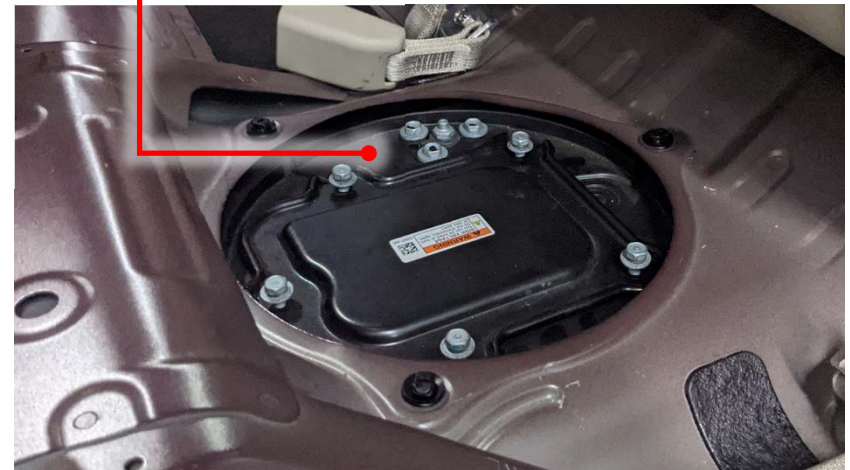

### Battery Discharging (continued)

6. Push and slide the tab on service plug B until you hear a click.



7. Raise the lever and remove service plug B.



*Continued on the next page.*





### Battery Discharging (continued)

8. Push and slide the tab on service plug A until you hear a click.



9. Raise the lever and remove service plug A.



*Continued on the next page.*





### Battery Discharging (continued)

10. Open the trunk by pressing the release button on the remote for approximately 1 second, by pressing the trunk opener button in the driver's door, or by pressing the release button on the trunklid.

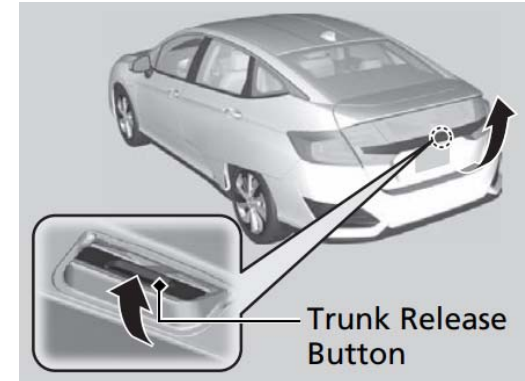
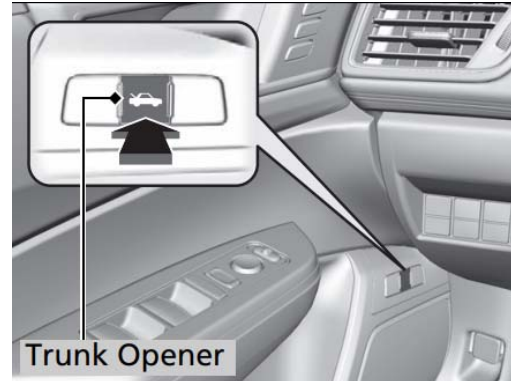
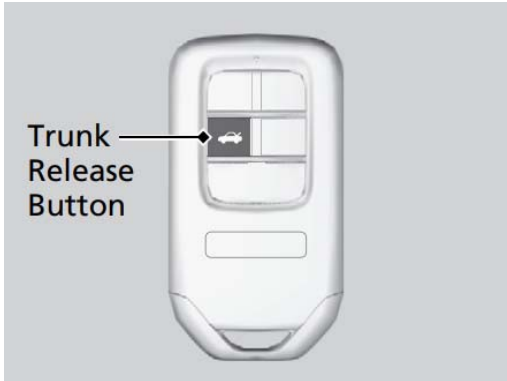

11. Fold down both rear seatbacks by pulling the release levers in the trunk.

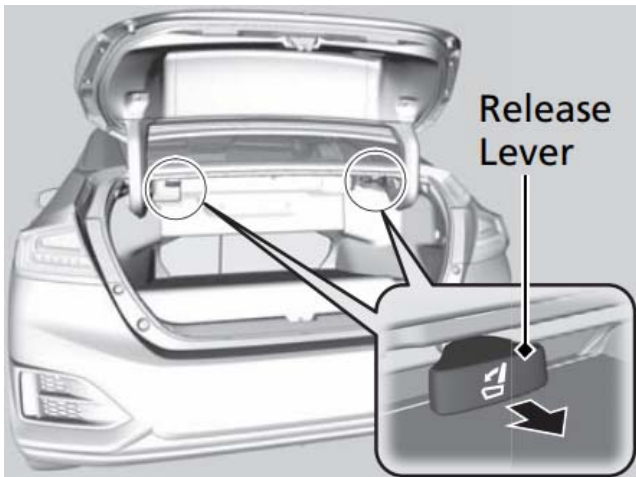

*Continued on the next page.*



### Battery Discharging (continued)

12. Remove the clips securing the trunk front trim.

Fastener Locations

▷ : 4

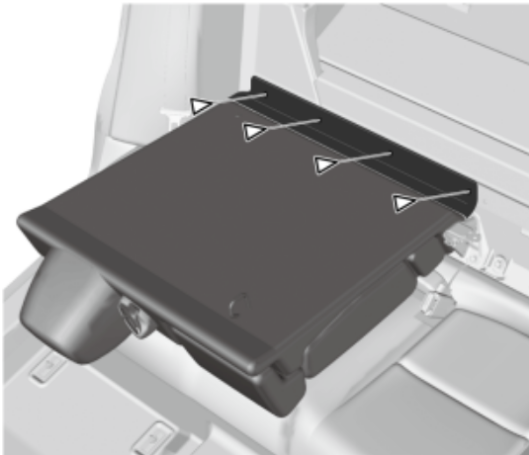

Fastener Locations

▷ : 3

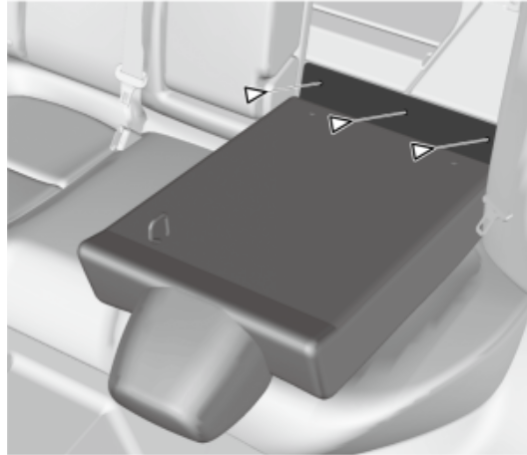

13. Remove the trunk front trim to access the service plug hole cap.



Continued on the next page.



### Battery Discharging (continued)

14. Remove the service plug cover 10 mm bolts, then remove the service plug cover.

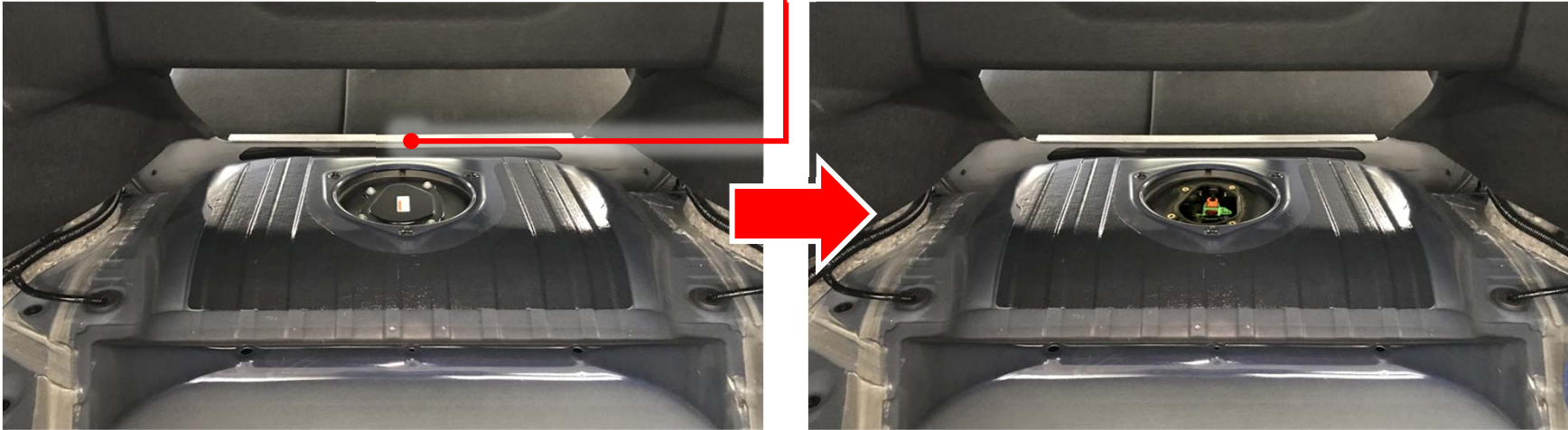

15. Push and slide the tab on service plug C until you hear a click.

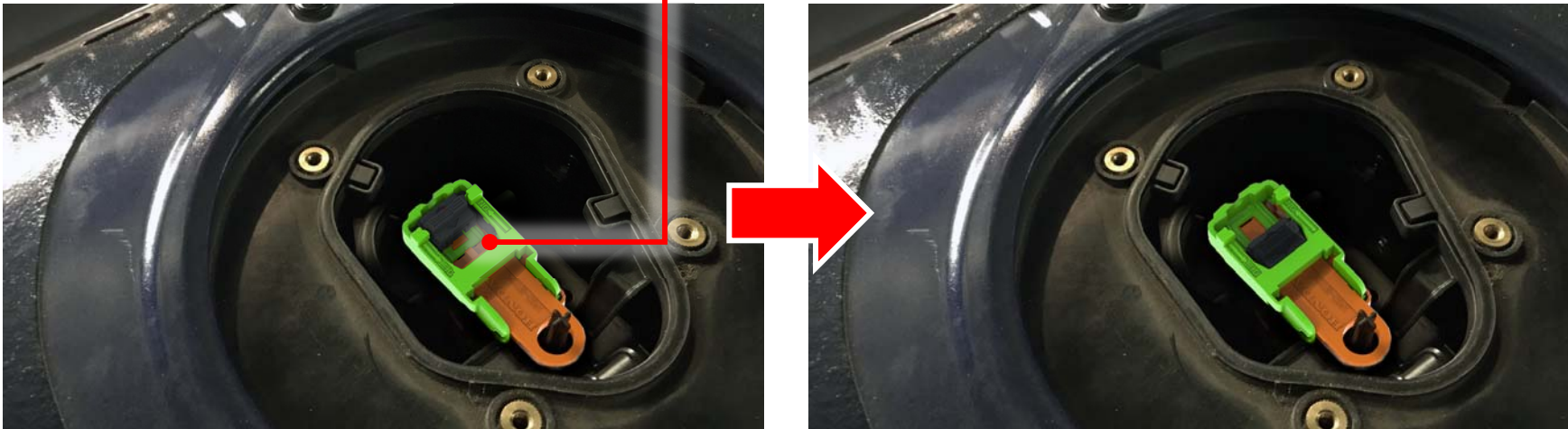

*Continued on the next page.*



### Battery Discharging (continued)

16. Raise the lever and remove service plug C.

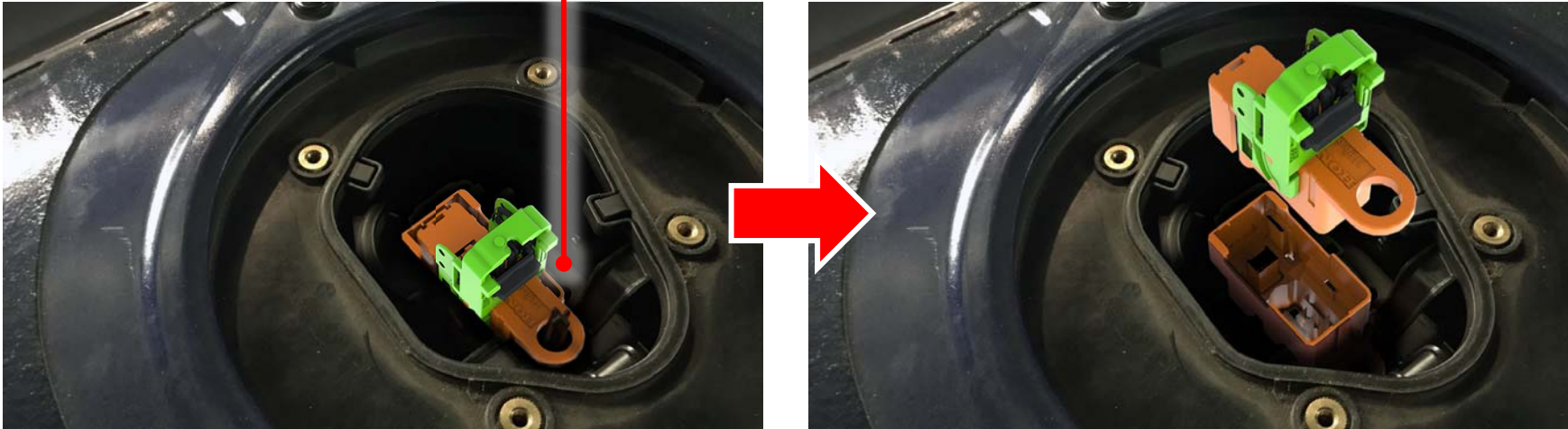

17. Set up a pool approximately **18 feet long x 8 feet wide x 3.7 feet high** in a well-ventilated outdoor area.  
18. Use a forklift or similar equipment to place the vehicle in the center of the pool.

*Continued on the next page.*





### Battery Discharging (continued)

19. Fill the easy set pool with water from a fire hydrant, well water, or pond water until the high voltage battery is completely submerged. If there is a risk of water leakage from the easy set pool, place a thick plastic sheet under the pool.

*Never use seawater or any water containing salt.*

20. Continue filling the easy set pool to a minimum depth of 2.7 feet (824 mm) until the high voltage battery is completely submerged.

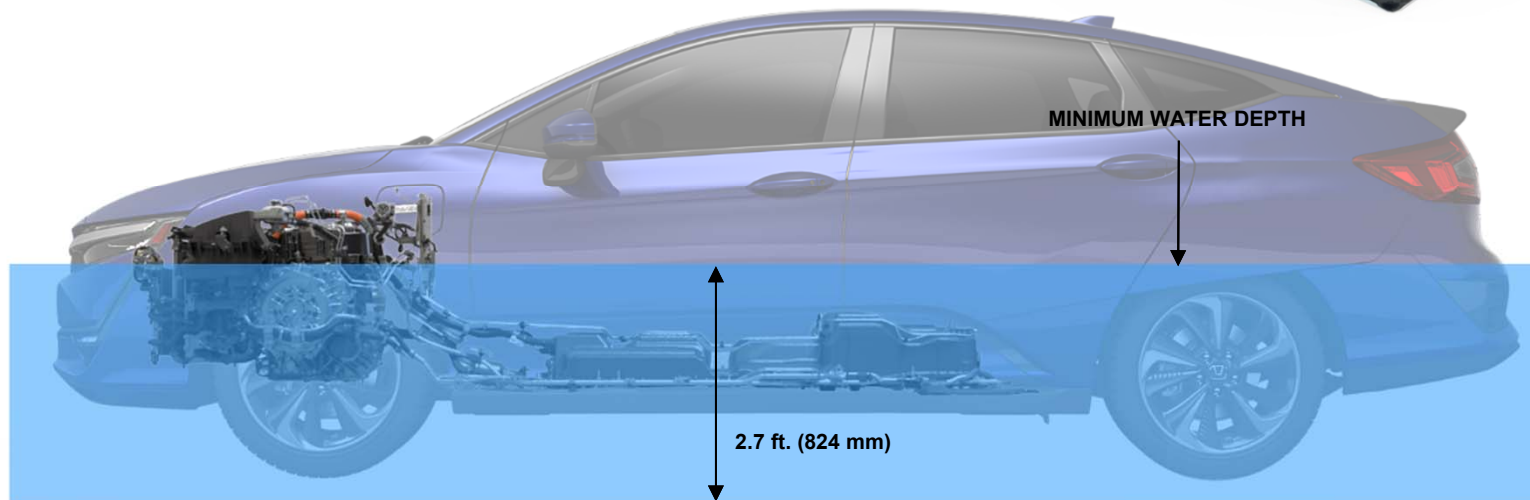

21. Maintain this water level for at least 3.5 days. If the water level drops below the minimum specified level, add fresh water.

*Since the water used for discharging the battery is converted to an aqueous solution containing metals such as Phosphorus (P) and Lithium (Li), dispose of it properly as an industrial waste according to local regulations.*



### Lithium-Ion Battery Fumes or Fire

A damaged high-voltage lithium-ion battery can emit toxic fumes, and the organic solvent used as electrolyte is flammable and corrosive. Responders should wear appropriate personal protective equipment. Even after a lithium-ion battery fire appears to have been extinguished, a renewed or delayed fire can occur. The battery manufacturer cautions responders that extinguishing a lithium-ion battery fire will take a large and sustained volume of water.

***In order to minimize the possibility of collateral fire damage, responders should always ensure that an Honda Clarity Electric with a damaged battery is kept outdoors and far away from other flammable objects.***



### Lithium-Ion Battery Fluid

Avoid contact with the high-voltage battery fluid. The high-voltage battery contains a flammable electrolyte that could leak as a result of a severe crash. Avoid any skin or eye contact with the electrolyte as it is corrosive. If you accidentally touch it, flush your eyes or skin with a large quantity of water for at least **5 minutes** and seek medical attention immediately.

### Electric Shock

Unprotected contact with any electrically charged high-voltage component can cause serious injury or death. Receiving an electric shock from a Honda Clarity Electric, however, is highly unlikely because of the following:

- Contact with the battery module or other high-voltage components can only occur if they are damaged and the contents are exposed, or if they are accessed without following proper precautions.
- Contact with the electric motor can only occur after one or more components are removed.
- The high-voltage cables can be easily identified by their distinctive orange color, and contact with them can be avoided.

***If severe damage causes high-voltage components to become exposed, responders should take appropriate precautions and wear appropriate insulated personal protective equipment.***



### Disposal

The lithium-ion battery, the high-voltage battery fluid, and the water used to discharge the battery must be properly disposed of as industrial waste according to local regulations.

### Seat Belts and Airbags

The Honda Clarity Electric is equipped with lap/shoulder belts in all seating positions. The front seat belts are equipped with pyrotechnically activated tensioners that help tighten the seat belt in a sufficient crash.

In addition, the Honda Clarity Electric is equipped with the following airbags:

- Front Airbags - Driver/Front Passenger
- Side Airbags - Driver/Front Passenger
- Side Curtain Airbags - Driver's Side/Passenger Side (Both Rows)
- Knee Airbag - Driver

In a collision severe enough to deploy one or more of the airbags, the Honda Clarity Electric electrical system is designed to automatically open the high-voltage electrical contactors. This disconnects the high-voltage battery from the other high-voltage components and stops the flow of electricity in the high-voltage cables.

**Responders should always assume, however, that the high-voltage system is powered on and take the appropriate action described later in this guide to power off the system.**

It takes up to **3 minutes** for the airbags and tensioners to power off after the 12-volt system has been turned off by following the emergency shutdown procedures provided later in this guide.

1. Front Airbags
2. Driver's Knee Airbag
3. Side Airbags
4. Side Curtain Airbags
5. SRS Unit
6. Front Seat Belt Tensioners
7. Driver's Seat Position Sensor
8. Passenger's Seat Weight Sensor
9. Impact Sensor
10. Rollover Sensor

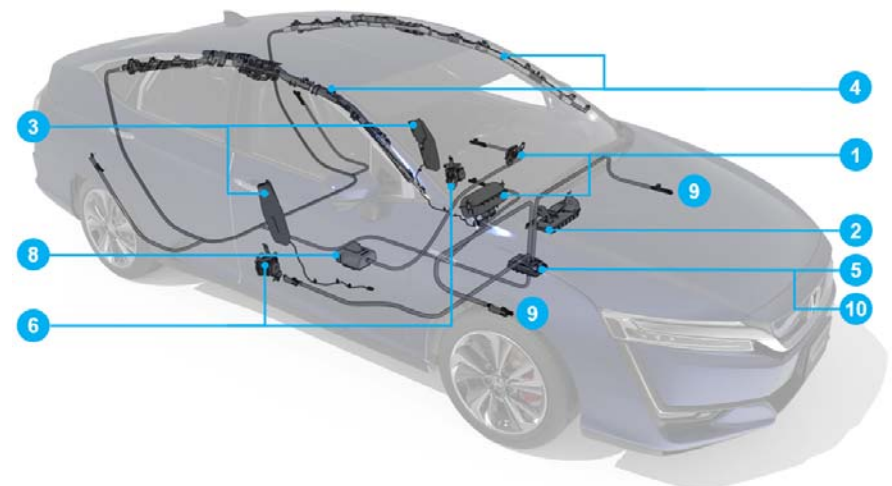
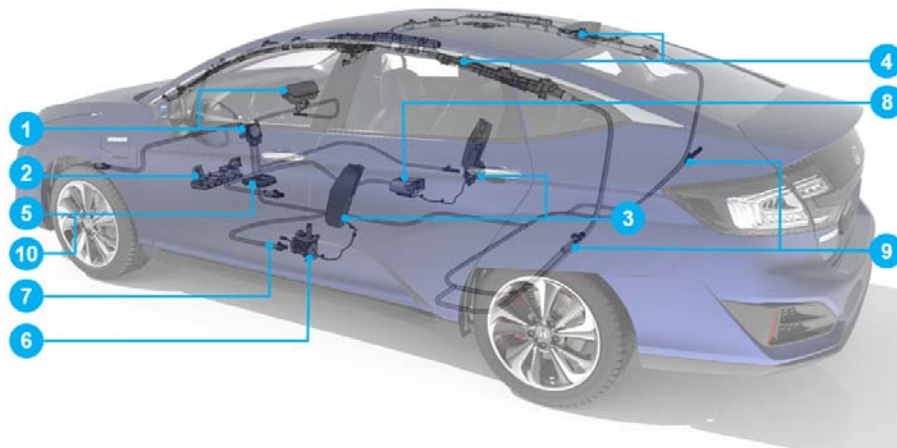

### Vehicle Collision

In the event of a crash, the supplemental restraint system (SRS) unit makes a judgment based on input from the impact sensors. If the input values meet various threshold requirements, the SRS unit sends a signal to the high-voltage battery electronic control unit (ECU). The high-voltage battery ECU then turns off the high-voltage battery contactors, stopping the flow of electrical current from the high-voltage battery.







When responding to an incident involving a Honda Clarity Electric, we recommend that emergency personnel follow their organization's standard operating procedures for assessing and dealing with vehicle emergencies.

Honda recommends that responders follow the procedures in this guide to avoid potentially lethal shock from high voltage.





### Components

- High-Voltage Components 
- 12-Volt Battery 
- SRS Components 
- Gas Strut 
- Reinforcement 
- Seat Belt Pretensioners 

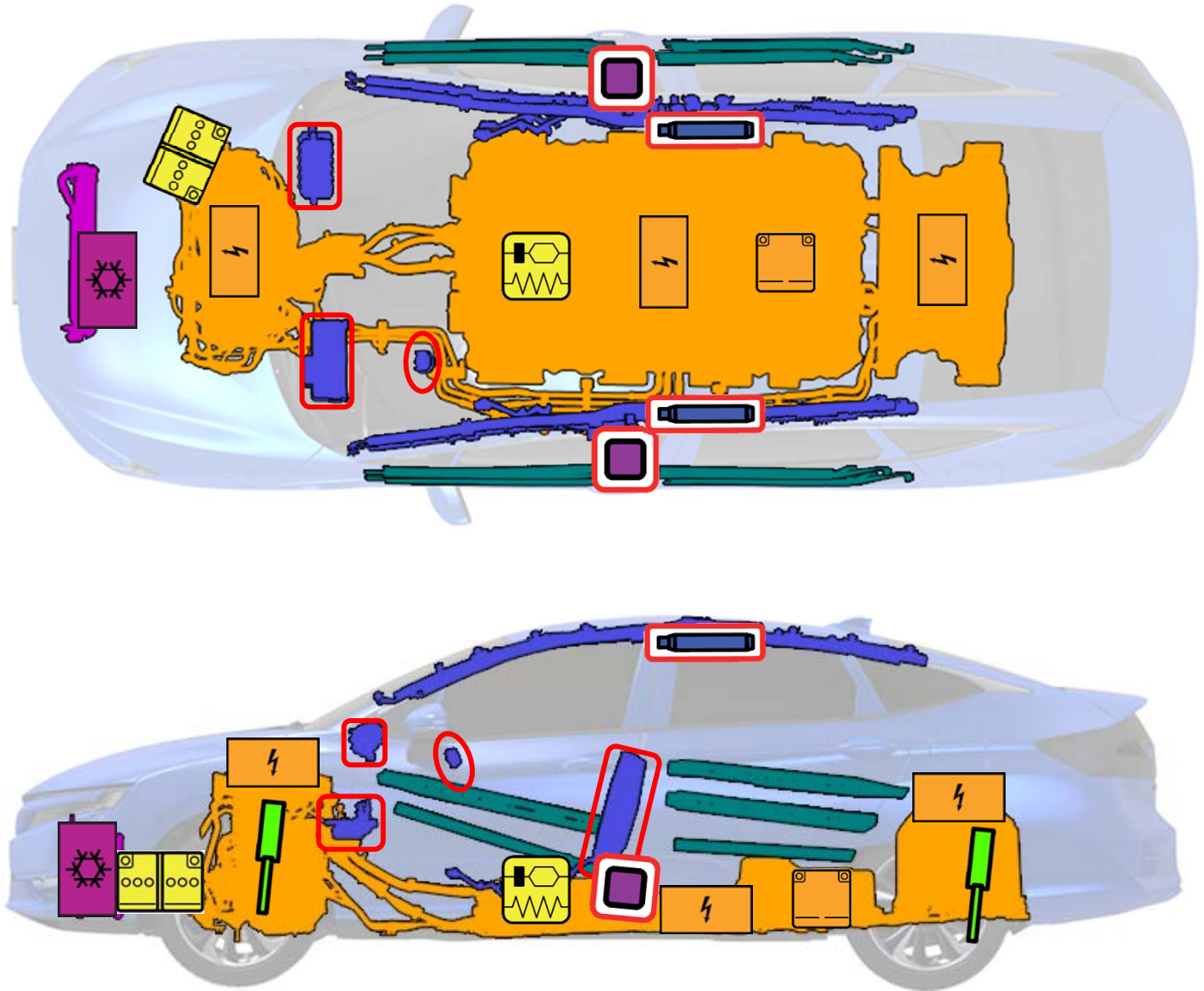

### Dealer Inspection and Repair

A damaged Honda Clarity Electric should be taken to an authorized Honda dealer for a thorough inspection and repairs. For questions or to locate an authorized Honda dealer, please contact your local Honda dealer or Honda Automobile Customer Service at **(800) 999-1009**.



### High-Voltage Battery Recycling

The high-voltage lithium-ion battery requires special handling and disposal. If disposal is necessary, please contact your local Honda dealer or American Honda's Hybrid Battery Consolidation Center at **(800) 555-3497**.



BLUE SKIES FOR  
OUR CHILDREN

Pictogram	Name	Pictogram	Name
	Hood release/opener control		SRS control unit
	Tailgate/cargo area opener control		High-voltage battery pack
	Power switch		High-voltage component
	Keyless operation key distance		High-voltage power cable
	Fuse box disabling high-voltage		Air-conditioning component
	Cable to cut to disconnect high-voltage		General warning
	High-voltage service plug		Electricity or dangerous voltage
	Steering wheel height adjustment control		Use a thermal infrared camera
	Seat height adjustment control		Use water to extinguish the fire
	Forward or backward seat adjustment control		Use ABC powder to extinguish the fire
	Lifting point		Flammable
	Airbag		Gases under pressure
	Airbag inflator		Corrosive
	Seat belt pretensioner		Hazardous to human health
	Gas strut		Environmental hazard
	12-volt battery		

**HONDA**