

Emergency Response Guide



2014 Accord Plug-In Hybrid (P-HEV)

Prepared for Fire Service, Law Enforcement, Emergency Medical, and Professional Towing Personnel by American Honda Motor Co., Inc.

Introduction

This guide has been prepared to assist emergency response professionals in identifying a Honda Accord P-HEV and safely respond to incidents involving this vehicle.

Copies of this guide and other Honda Emergency Response Guides are available for reference or downloading at <https://techinfo.honda.com>

For questions or to order printed copies of this guide, please contact your local Honda dealer or Honda Automobile Customer Service at (800) 999-1009.

Honda wishes to thank emergency response professionals for their concern and efforts in protecting Honda customers and the general public.

Contents

Vehicle Description

- Vehicle Overview
- Vehicle Type and Construction
- Vehicle Identification
- Key Components
- High Strength Steel
- Power Control Unit (PCU)
- 12-Volt Battery
- High-Voltage (HV) Battery Pack
- Electric Motor/Generator
- High-Voltage Cables

Occupant Protection Equipment

Recharging System

Potential Hazards

- Electric Shock
- Lithium-ion Battery Fumes or Fire

Emergency Procedures

- Vehicle Collision
- Submerged Vehicle
- Best Method for HV Shutdown
- Second-Best Method for HV Shutdown
- Extricating Occupants

Emergency Towing and Repairs

- Emergency Towing
- Dealer Inspection and Repair
- High-voltage Battery Recycling

Vehicle Description

Vehicle Overview

The Accord P-HEV is powered by a two-motor hybrid system, which consists of a 4-cylinder 2.0 liter gasoline engine teamed with a 124-kilowatt (kW) electric motor and a generator. The system allows the powertrain to move between all-electric drive, gasoline-electric hybrid drive, and direct engine drive. Electric driving is supported by a 6.7 kilowatt-hour (kWh) (320 volt) high-voltage (HV) lithium-ion (Li-Ion) battery mounted behind the rear seats. The battery is charged under some driving conditions and can also be charged using 120 or 240-volt AC charging systems.

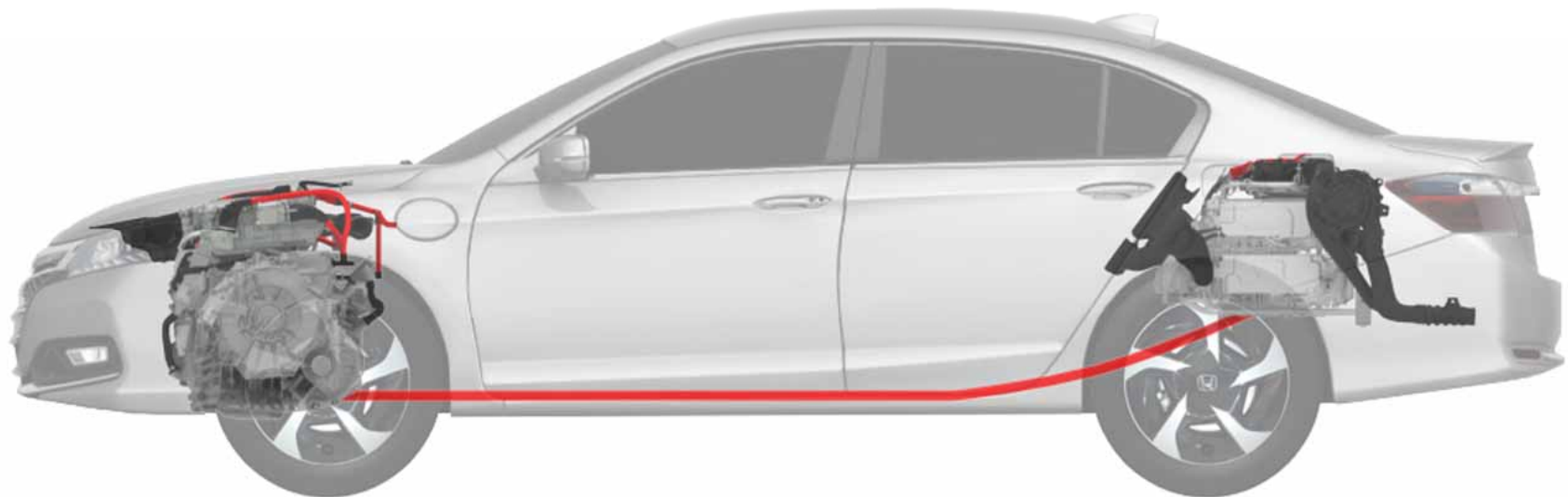

Vehicle Description

Vehicle Type and Construction

The Accord P-HEV is a four-door, five-passenger vehicle. Most of its structural components are made of steel. Other parts are made of aluminum and plastic.



Vehicle Description

Vehicle Identification

You can identify a Honda Accord P-HEV by the exterior “Hybrid ” marks located on the front fenders and the trunk lid. You can also identify an Accord Hybrid by the charge port located on the left front fender, and by a “Hybrid ” mark and orange cabling under the hood.



Vehicle Description

Key Components

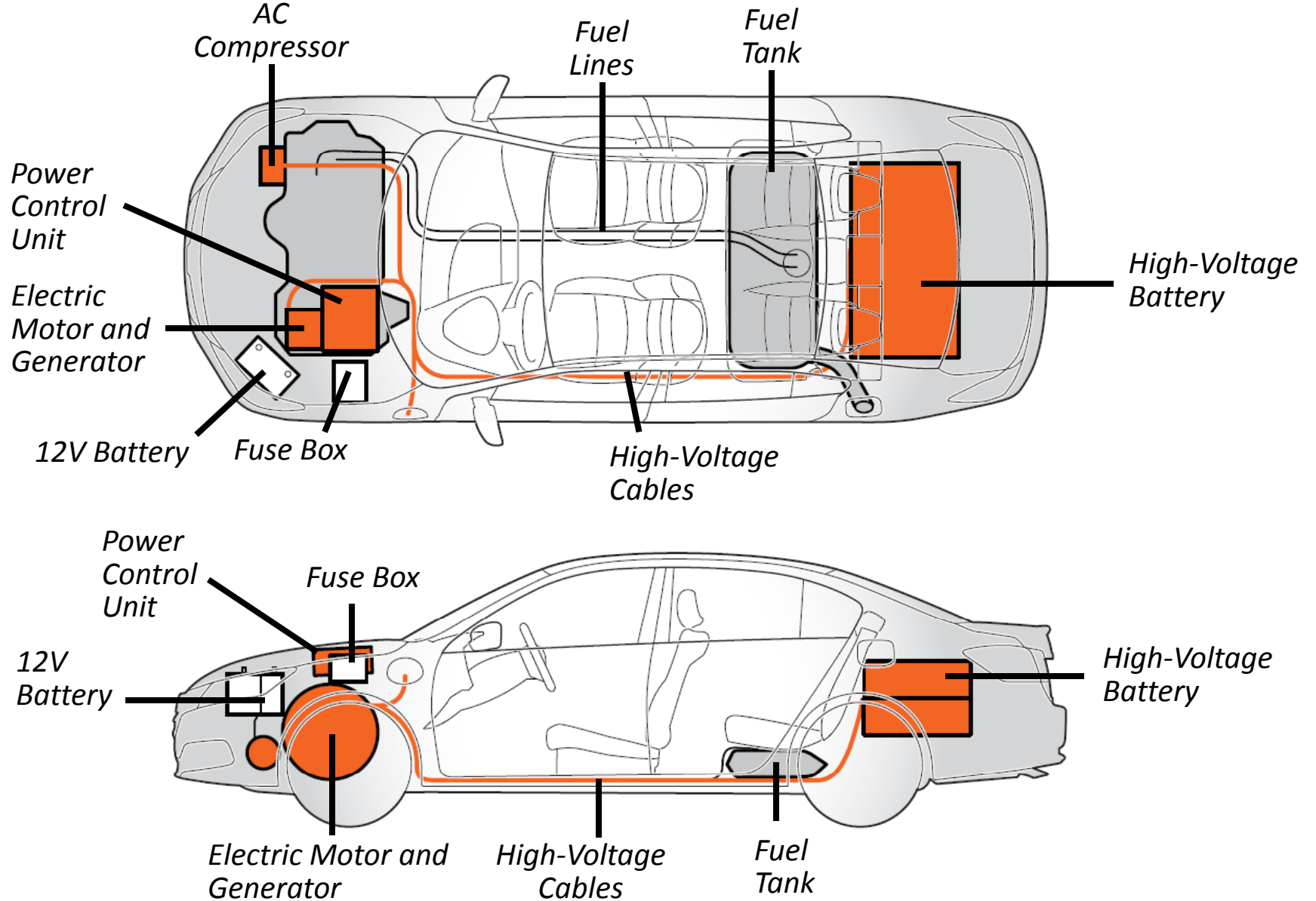

Vehicle Description

High Strength Steel

High strength steel is used in the colored areas.

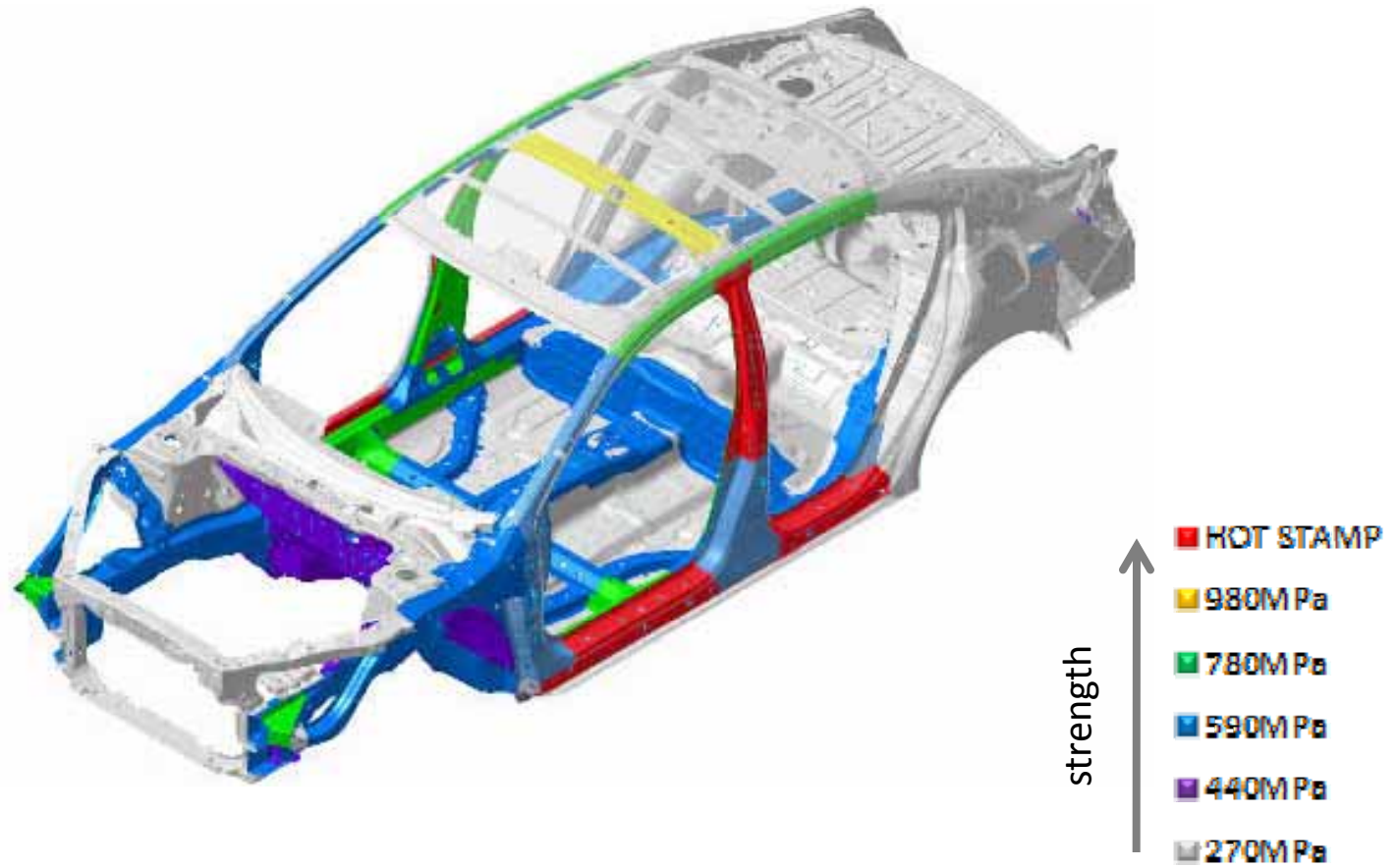

Vehicle Description

Power Control Unit (PCU)

The PCU is located under the hood on the driver's side directly above the electric generator and electric motor and adjacent to the 12V battery and the underhood fuse box. The PCU houses the traction motor/generator electronic control unit (ECU), the power distribution unit (PDU), and the voltage control unit (VCU). These components are non-serviceable, so the PCU should not be opened or disassembled.

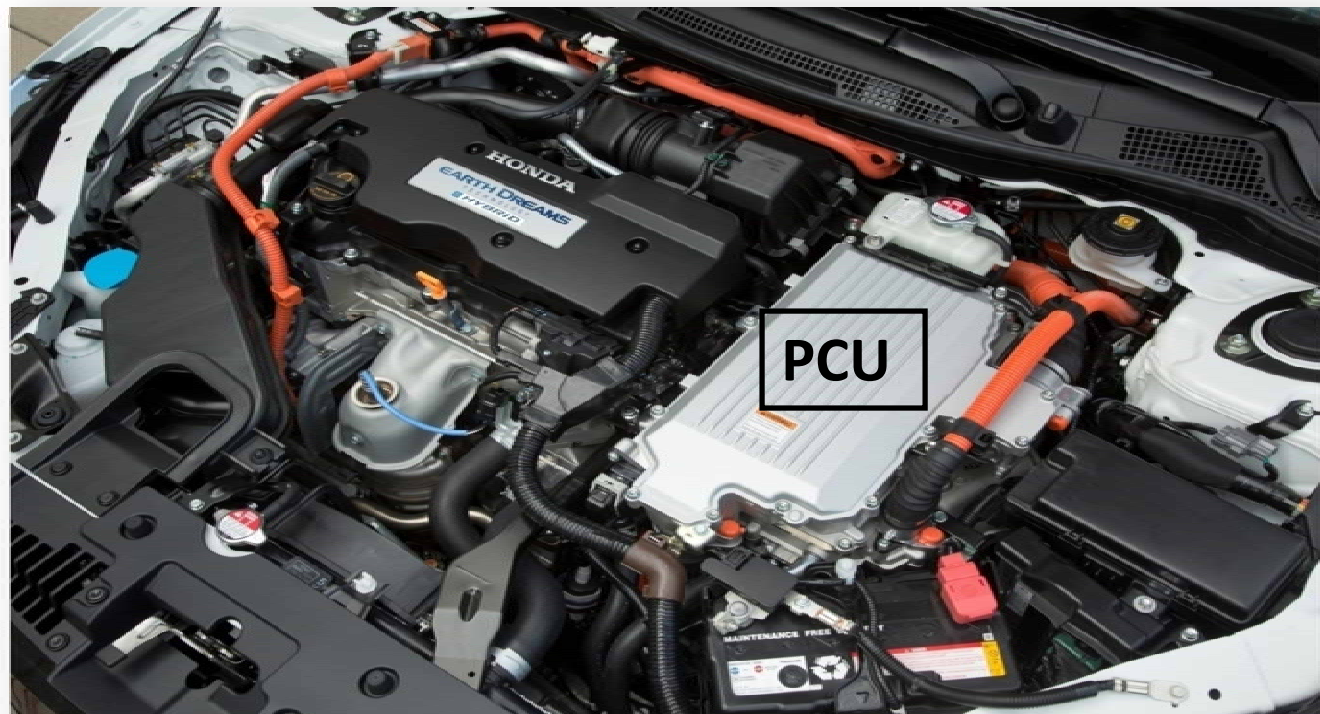

Vehicle Description

12-Volt Battery

A conventional 12-volt battery is located under the hood on the driver's side of the vehicle. This battery powers the airbags, lights, audio system, and other standard 12-volt system components. In an emergency situation, it may be necessary to disconnect or cut the 12-volt battery negative cable.



High-Voltage (HV) Battery Pack

A 6.7 kilowatt hour (kWh) (320V) high-voltage lithium-ion battery pack is located in a well protected area behind the rear seat. The battery is made up of 2 modules that each contain 50 individual 3.2-volt cells. The Intelligent Power Unit (IPU), the HV battery ECU, the battery contactors, a forced air cooling system, and other battery system controls are housed with the battery pack. Total voltage of the battery pack is approximately 320 volts.

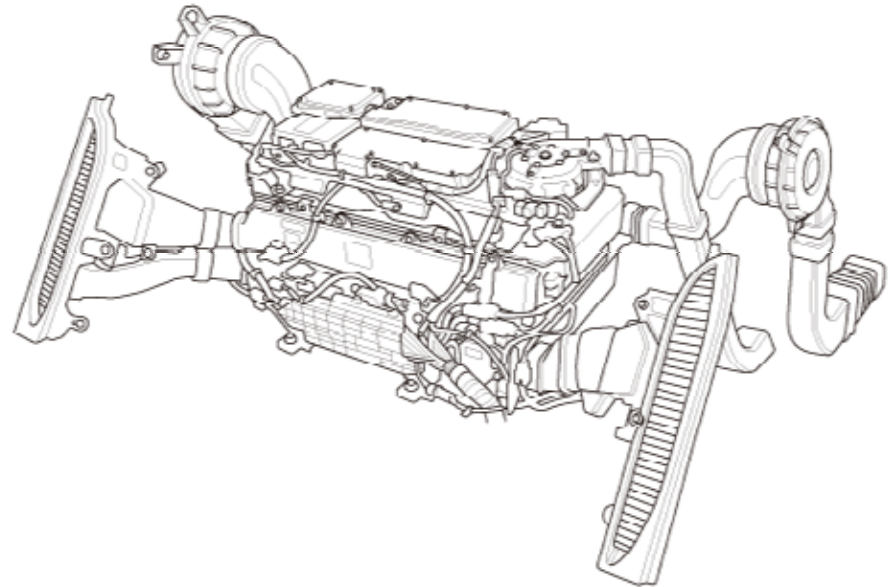

Vehicle Description

Electric Motor/Generator

The two-motor hybrid systems contains an electric motor and a generator. The electric motor propels the vehicle using electric power directly produced by the generator and/or supplied by the high-voltage (HV) battery.

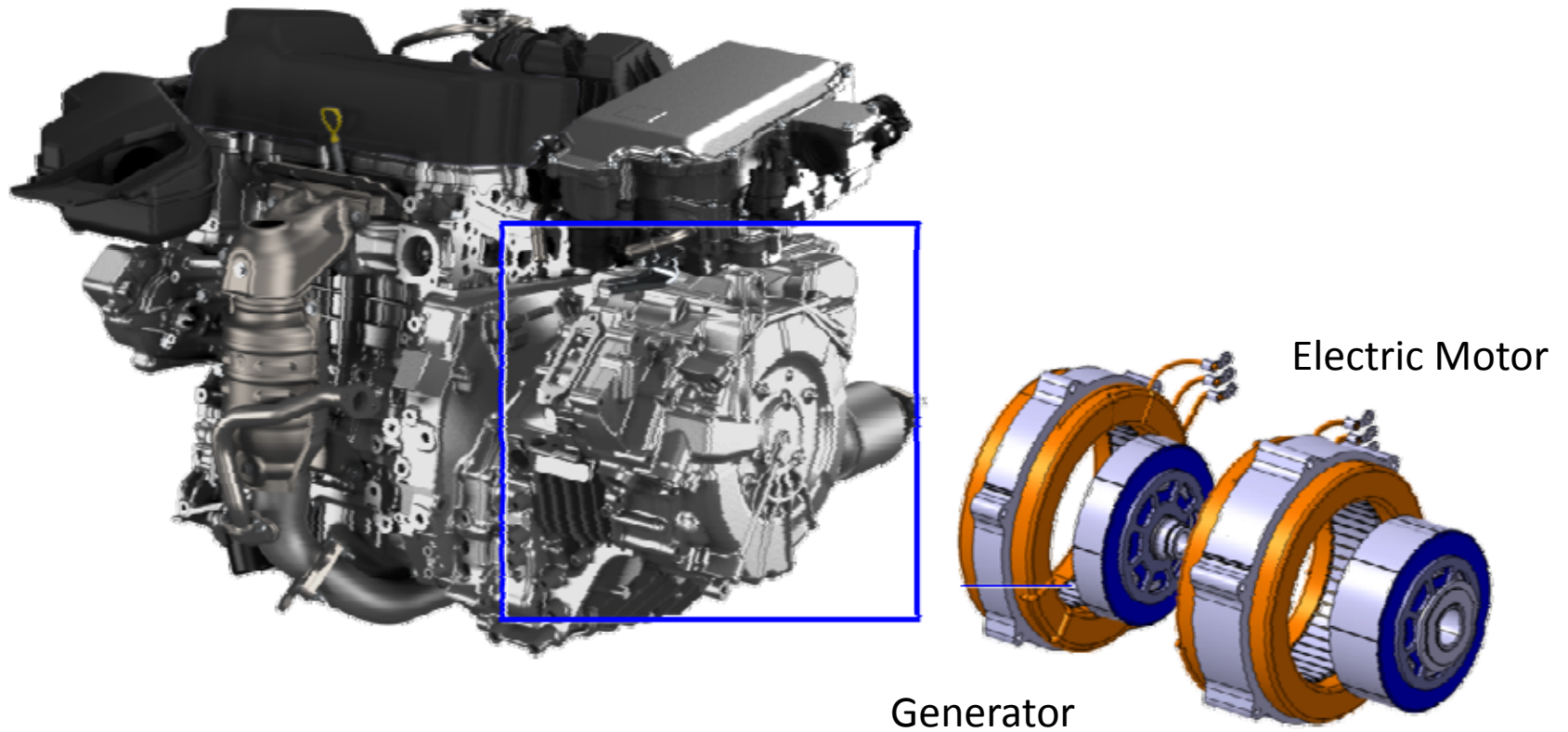

Vehicle Description

High-Voltage Cables

High-voltage flows through easy to identify heavy-duty orange cables. These cables are purposely routed through areas away from the usual cut points.



Occupant Protection Equipment

The Accord P-HEV is equipped with lap/shoulder belts in all five seating positions. Front seat belts are equipped with pyrotechnically activated tensioners that help tighten the seat belt in a crash. Front, front side, and side curtain airbags are also provided.

In a collision severe enough to deploy one or more of the airbags, the Accord P-HEV electrical system is designed to automatically open the high-voltage electrical contactors. This disconnects the high-voltage battery from the other high-voltage components and stops the flow of electricity in the high-voltage cables.

Responders should always assume, however, that the HV system is powered “on” and take the appropriate action described later in this guide to power the system “off.”

It takes about 3 minutes for the airbags and tensioners to de-power after the 12-volt system has been turned off by following the emergency shut-down procedures provided later in this manual.



Recharging System

The high-voltage (HV) battery can be recharged using either the 120-volt AC charge cord provided with the vehicle or by using approved 240-volt AC equipment. The vehicle's charge port is located behind a small door on the left front fender. Recharging can take as little as 3 hours when using a 240-volt AC 32-amp electric vehicle supply equipment.



Potential Hazards

Electric Shock

Unprotected contact with any electrically charged or “hot” high-voltage component can cause serious injury or death. Receiving an electric shock from a Accord P-HEV, however, is highly unlikely because of the following:

- Contact with the battery module or other high-voltage components only can occur if they are damaged and the contents are exposed or if they are accessed without following proper precautions.
- Contact with the electric motor only can occur after one or more components are removed.
- The high-voltage cables can be easily identified by their distinctive orange color and contact with them can be avoided.

If severe damage causes high-voltage components to become exposed, responders should take appropriate precautions and wear appropriate insulated personal protective equipment.



Potential Hazards

Lithium-ion Battery Fumes or Fire

A damaged high-voltage lithium-ion battery can emit toxic fumes and the organic solvent used as electrolyte is flammable and corrosive, so responders should wear appropriate personal protective equipment. Even after a lithium-ion battery fire appears to have been extinguished, a renewed or delayed fire can occur. The battery manufacturer cautions responders that extinguishing a lithium-ion battery fire will take a large and sustained volume of water.

Responders should always ensure that a Accord P-HEV with a damaged battery is kept outdoors and far away from other flammable objects in order to minimize the possibility of collateral fire damage should the battery catch on fire.



Emergency Procedures

Vehicle Collision

In the event of a crash, the airbag control unit makes a judgment based on input from the impact sensors, and if the input values meet various threshold requirements, the airbag control unit sends a signal to the high-voltage battery ECU. The battery ECU then turns off the high-voltage battery contactors stopping the flow of electrical current from the high-voltage battery.

When responding to an incident involving a Honda Accord P-HEV, we recommend that emergency personnel follow their organization's standard operating procedures for assessing and dealing with vehicle emergencies.

Given our knowledge of the Accord P-HEV, we also recommend that responders follow the procedures on the following pages to avoid potentially lethal shock by high-voltage.

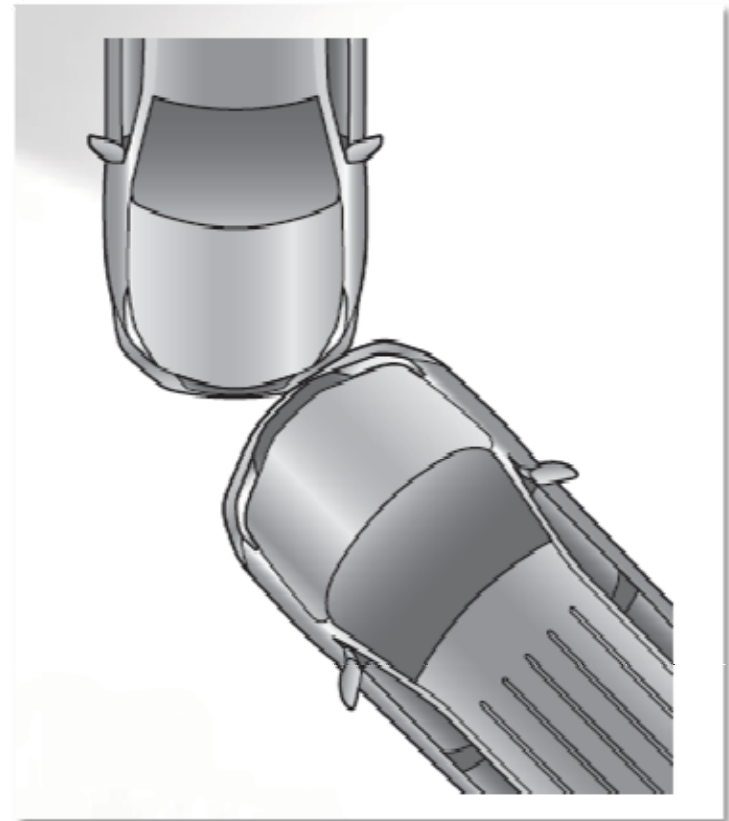

Emergency Procedures

Submerged Vehicle

If a Accord P-HEV is submerged or partly submerged in water, first pull the vehicle out of the water. Then shut down the high-voltage system using one of the two procedures described on the following pages.

Absent severe damage to the vehicle, there is no risk of electric shock from touching the car's body or framework — in or out of the water.

If the high-voltage battery was submerged, you may hear noises from the battery as the cells are being discharged from shorting.

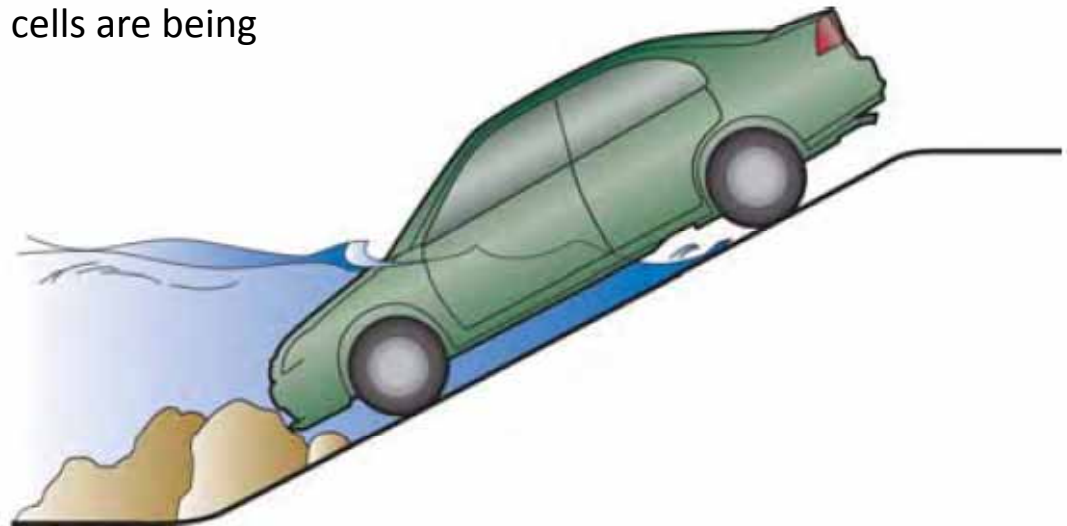

Emergency Procedures

Preventing Current Flow Through High-Voltage Cables

Before attempting to rescue occupants or move a damaged Accord P-HEV, you should reduce the potential for current to flow from the electric motor or the battery module through the high-voltage cables.

There are ***two recommended methods*** for preventing current flow. These are discussed on the following pages.

Emergency Procedures

BEST METHOD for HV Shutdown

Push and hold the Start/Stop button for 3 seconds.

This simple action turns off the gasoline engine and immediately shuts down the high-voltage system controllers, thereby preventing current flow into the cables. It also cuts power to the airbags and the seat belt tensioners, though these pyrotechnic devices have a three minute deactivation time.

To prevent accidental restarting, you must remove the keyless remote from the vehicle and move it at least 20 feet away.

If you cannot locate the keyless remote, you should perform the **SECOND-BEST METHOD** (for preventing high-voltage current flow) on the following page.



Push and hold the start/stop button for 3 seconds

Emergency Procedures

SECOND-BEST METHOD for HV Shutdown

Cut the negative 12-volt battery cable and disconnect the underhood fuse box from the DC to DC Converter.

Together, cutting the negative 12-volt battery cable and disconnecting the underhood fuse box from the DC to DC Converter turns off the gasoline engine and immediately shuts down the high-voltage system controllers, thereby preventing current flow into the high-voltage cables. It also cuts power to the airbags and the seat belt tensioners, though these pyrotechnic devices have a three minute deactivation time.

1. Locate the 12-volt battery and cut the negative cable.

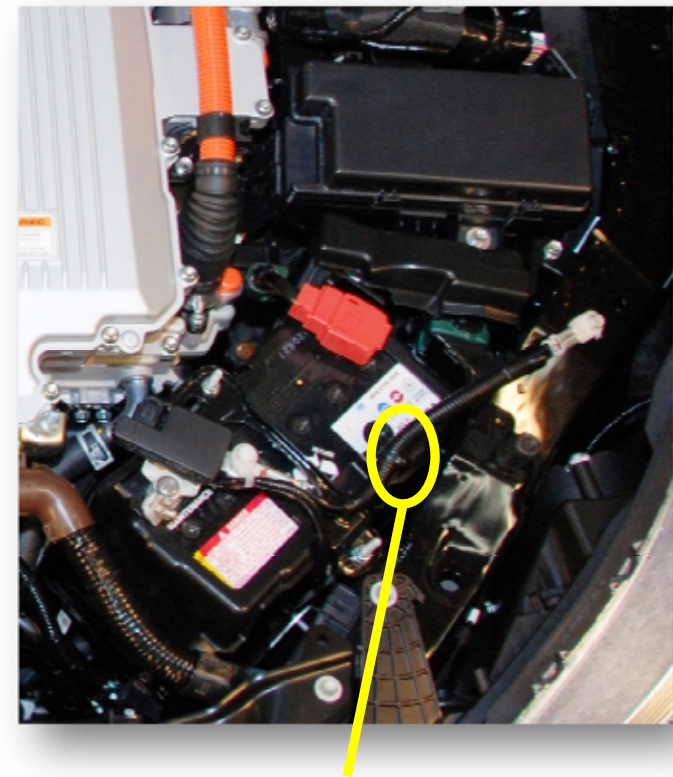

Cut the negative 12V battery cable.

Continued on the next page

Emergency Procedures

2. Locate the underhood fuse box and either;
 - a) cut the cable that connects the fuse box to the DC to DC Converter, or
 - b) remove the fuse box cover and remove the main fuse using a phillips screwdriver.

If cutting the DC to DC Converter Cable, do not allow the cutting tool to contact any surrounding metal parts; electrical arcing could occur which can ignite any flammable vapors.

NOTE: If you cannot perform either method to stop the engine and prevent current flow into the high-voltage cables, use extreme care and do not touch damaged cables as they may be “hot.”

Continued on the next page



Underhood Fuse Box

DC to DC Converter Cable

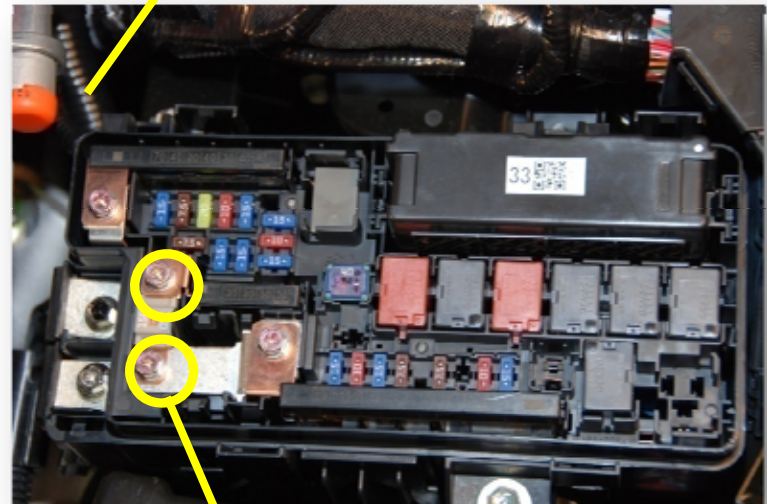

Main Fuse Screws / Main Fuse

Emergency Procedures

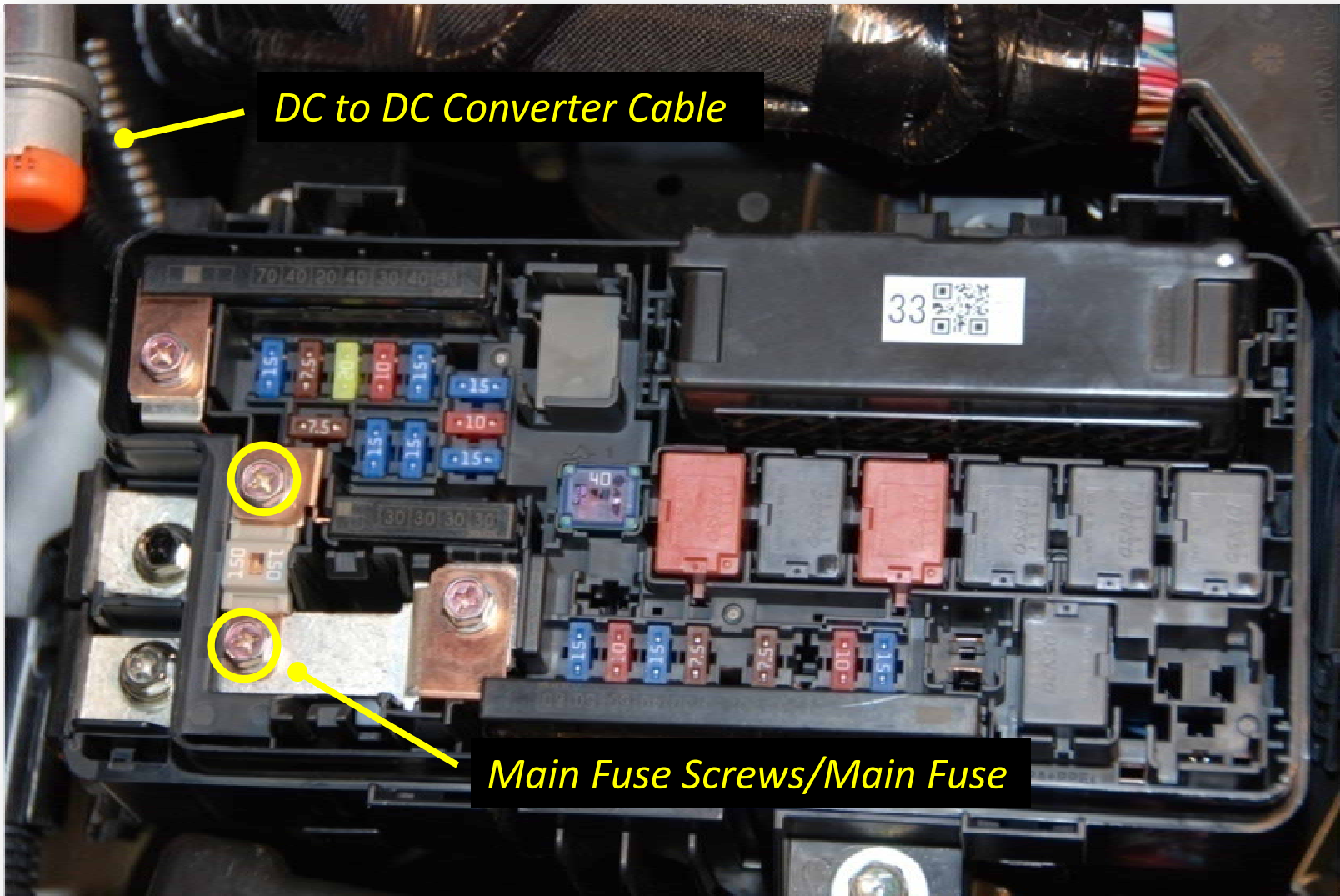

Emergency Procedures

Extricating Occupants

If you need to cut the vehicle body, or use Jaws-of-Life equipment to remove occupants, be sure to stay within the cut zone indicated in the illustration below.

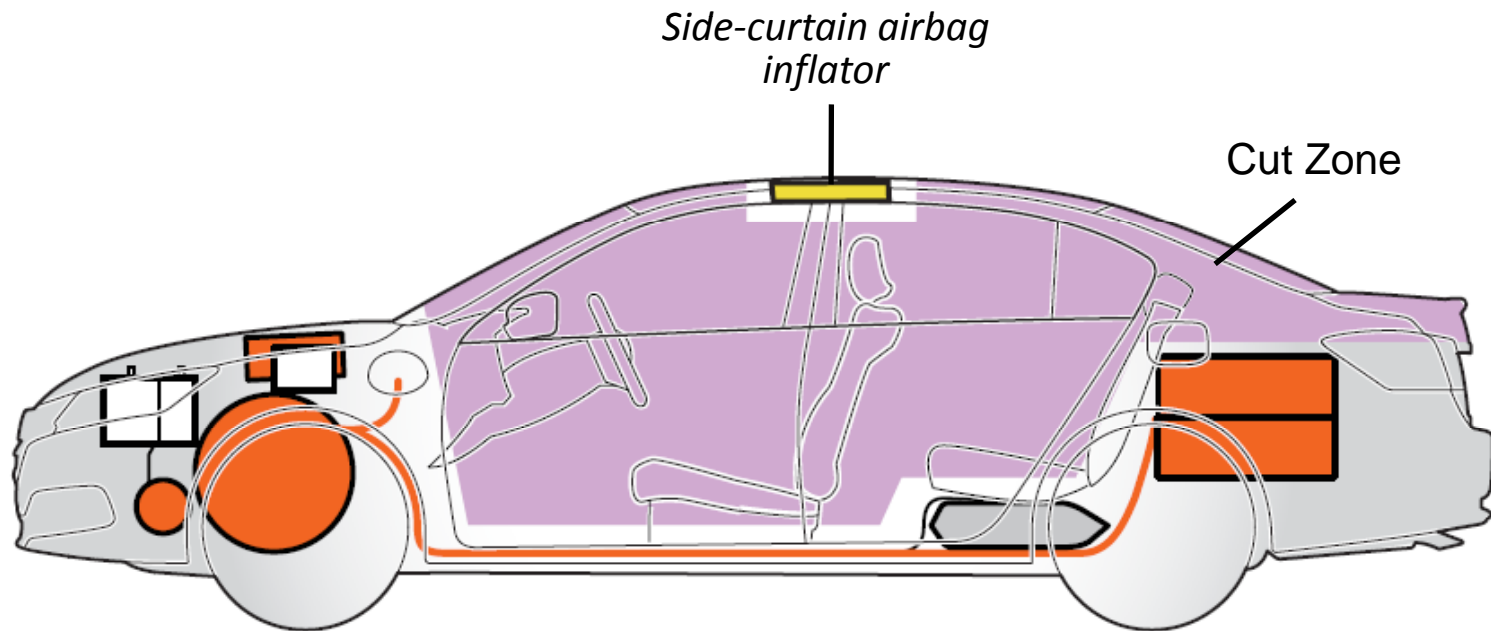

Emergency Towing & Repairs

Emergency Towing

The preferred method is to use a flat bed tow truck. If wheel lift equipment must be used, be sure to suspend the front wheels and release the parking brake.

Be aware that when rolling a damaged Accord P-HEV with the front (drive) wheels on the ground, the electric motor can produce electricity and remains a potential source of electric shock even when the high-voltage system is turned off.

Dealer inspection and Repair

A damaged Accord P-HEV should be taken directly to a Honda Accord P-HEV dealer for a thorough inspection and, if appropriate, any necessary repairs.

High-Voltage Battery Recycling

The high-voltage lithium-ion battery requires special handling and disposal. Contact an authorized Honda dealer or American Honda at (800) 555-3497 for instructions.

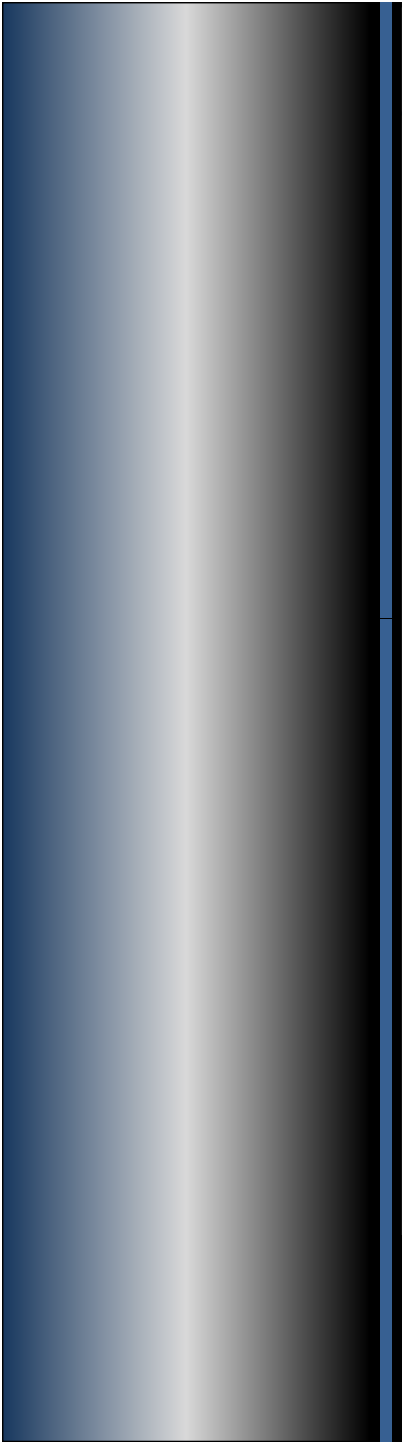

Copyright 2013, American Honda Motor Co., Inc.

Y0961
