

NUMBER: 31-001-20

GROUP: 31 - Collision Bulletins

DATE: February 11, 2020

This bulletin is supplied as technical information only and is not an authorization for repair. No part of this publication may be reproduced, stored in a retrieval system, or transmitted, in any form or by any means, electronic, mechanical, photocopying, or otherwise, without written permission of FCA US LLC.

This bulletin supersedes Service Bulletin 31-002-13, dated January 31, 2013, which should be removed from your files. This is a complete revision and no asterisks have been used to highlight revisions.

SUBJECT:

Blending Clearcoat During The Refinish Process

OVERVIEW:

This bulletin involves discussing FCA US LLC position against the use of partial clearcoat blending.

MODELS:

1996 - Current (All) All FCA Group Vehicles

NOTE: This bulletin applies to vehicles within the following markets/countries: North America, APAC, EMEA and LATAM.

DISCUSSION:

Partial clearcoat blending is not an approved warranty repair process for FCA vehicles.

- Partial clearcoat blending is a process that generally involves adding solvents to a paint manufacturers clearcoat mixing formula to reduce the viscosity. This will not only degrade the durability of materials but it could also produce additional emissions.
- Partial clearcoat blending is achieved by adopting processes that are typically used to transition basecoat color on repair areas.
- Clearcoat should always be applied to the entire surface area of a body panel and mixed to manufacturers specifications.
- Any vehicle repaired with the partial clearcoat blending process will prematurely fail and eventually result in a clearcoat delamination condition.
- An example of partial clearcoat blending is shown in (Fig. 1) .

As shown in (Fig. 1) clearcoat is not applied to the entire quarter panel surface area, but only to a small portion. The repair area will initially appear sufficient but depending on how the process was performed the repair area will begin to degrade in 6 months to 3 years.

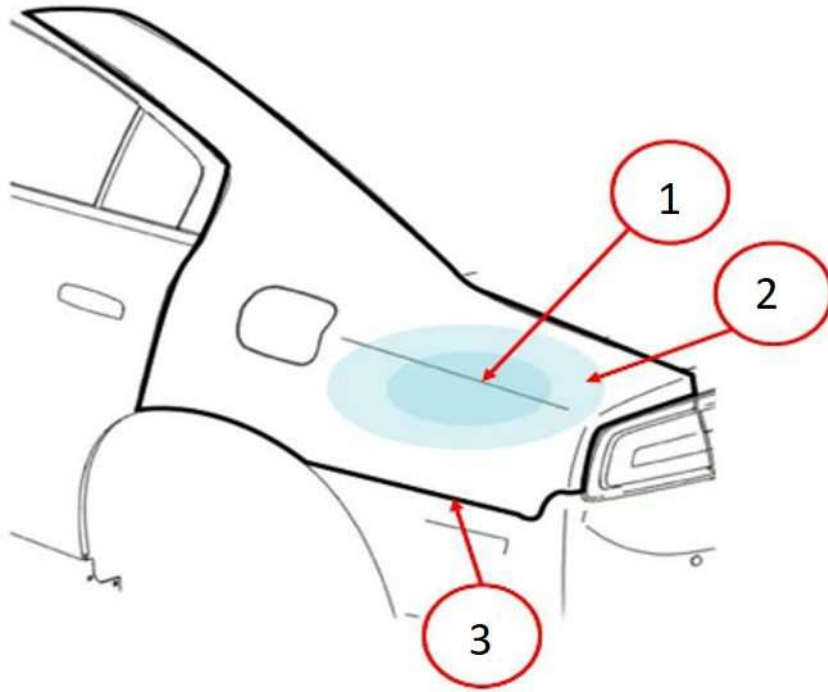

Fig. 1
Partial Clearcoat Blended Panel

- 1 - Basecoat
 - 2 - Clearcoat
 - 3- Left Quarter Panel
-

Clearcoat has been applied to the entire quarter panel in (Fig. 2) and basecoat was applied to cover the repair area, which is the proper repair process.

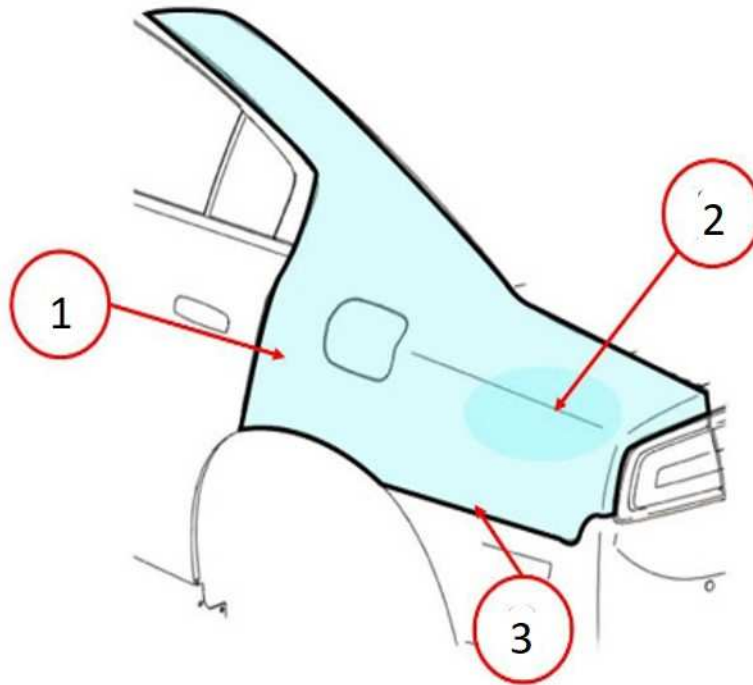

Fig. 2
Complete Application

- 1 - Clearcoat
- 2 - Basecoat
- 3- Left Quarter Panel

NOTE: This figure is used for demonstration purposes only. Most quarter panel repairs require clearcoat to be applied to the entire side aperture which typically ends at the cowl adjacent to the front fender.

POLICY:
Information Only.