

Body Repair Manual Welding & Sectioning Guideline Revisions

Supersedes original publication, issued October 2019; See REVISION SUMMARY

REVISION SUMMARY

Under **SPOT WELDING CONDITIONS FOR 1,500 MPA ULTRA HIGH-STRENGTH STEEL PARTS**, information was added to the table and highlighted in **yellow**.

OVERVIEW

The following are general guidelines for welding and sectioning Acura vehicles. It also lists the most current, Acura approved methods and materials. The information listed applies to all models and supersedes previously published information in the body repair manuals.

APPROVED WELDING METHODS

MAG butt welding is an approved repair method for steel parts up to and including 780 MPa.

- The table below lists approved welding methods.
- To minimize the heat-affected zone (HAZ), butt welds on 780 MPa steel must be done as quickly as possible, while maintaining adequate penetration.
- MAG plug welding is allowed on 1,500 MPa (hot stamp) steel parts in **select** locations **only** as specified in the model specific body repair manual.
- Welding instructions must be followed exactly as specified to ensure adequate weld strength.

Steel Part Tensile Strength (MPa)	Welding Method		
	Spot Weld	MAG Welding	
		Plug	Butt
<590	O	O	O
590	O	O	O
780	O	O	O
980	O	O	X
1,500	O	O*	X

Welding Methods for Steel Parts

O = Approved

X = Not Approved

O* = Approved Only as Specified In body repair manual

WELD-THROUGH PRIMER GUIDELINES

- When doing squeeze-type resistance spot welding (STRSW), apply a zinc-rich weld-through primer, to bare steel mating surfaces areas being welded and wipe off any excess. Use approved respiratory protection when working around these primers.
- Weld-through primer should **never** be used when doing MAG plug, MAG butt, or MIG brazing. Studies have shown that weld-through primers can negatively affect weld or joint quality.
- When doing MAG plug and butt welding, or MIG brazing, remove only enough of the factory e-coat to allow bare metal in the heat affected area of the weld. Then, apply epoxy primer over the completed weld joint, including all exposed steel.
- Refer to the body repair manual for complete information.

MAG WELDING WIRE SELECTION GUIDELINES

- Welding wire used during high-strength-steel repair must have a tensile strength equal to or greater than the lowest tensile strength of the parts being welded.
- Typical ER70S-6 wire has a minimum tensile strength of 70 ksi (483 MPa). This wire can be used when welding up to 440 MPa steel parts.
- This table shows the relationship of steel tensile strength (MPa) to the minimum welding wire tensile strength (ksi).

Steel Tensile (MPa)	Wire Tensile (ksi)
590	>86
780	>113
980	>142

(1,000 psi = 1 ksi)

HIGH-STRENGTH MAG WELDING WIRE

The following are approved high-strength-steel welding wires:

- Bohler Union X96
- Titan Technology EQ-5029X96
- Washington Alloy Eagle-Arc 980X

Product Name	Supplier	Contact Info
Bohler Union X96	Honda Snap-on	https://honda.snapon.com
	Pro Spot	https://prospot.com
	Chief Automotive	salesorders@chiefautomotive.com or 1-800-445-9262 ext : 2
Titan Technology EQ-5029X96	Equip Automotive	www.equipmyshop.com or call (866)362-4400
Washington Alloy Eagle-Arc 980X	Available at most welding supply locations	N/A

NOTES

- Bosch DS980J solid welding wire is no longer available but can still be used.
- All three options have a wire size of 0.8 mm (0.030 inch) in diameter and are used for welding joints in high-strength steel of 590 MPa and higher. It may be used for welding lower grade steel, but it is not necessary to provide the required strength.

1,500 MPA ULTRA-HIGH-STRENGTH (HOT STAMPING) WELDING CONDITIONS

For an explanation of 1,500 MPa ultra-high-strength (Hot Stamping) steel sheets, refer to the section, **Ultra-High-Strength Steel Sheets 1,500MPa grade (hot stamping)** in the body repair basics manual.

Removal of Aluminum Coating

1,500 Mpa hot stamp steel sheets have a 10-micron aluminum coating that must be removed (sanded off) from the weld zone of the panel before welding. Both exterior and mating surfaces requires the removal of coating. Failure to do so will create a weak weld and ultimately a failure of the joint.

NOTE

It is only necessary to sand down the area to be welded.

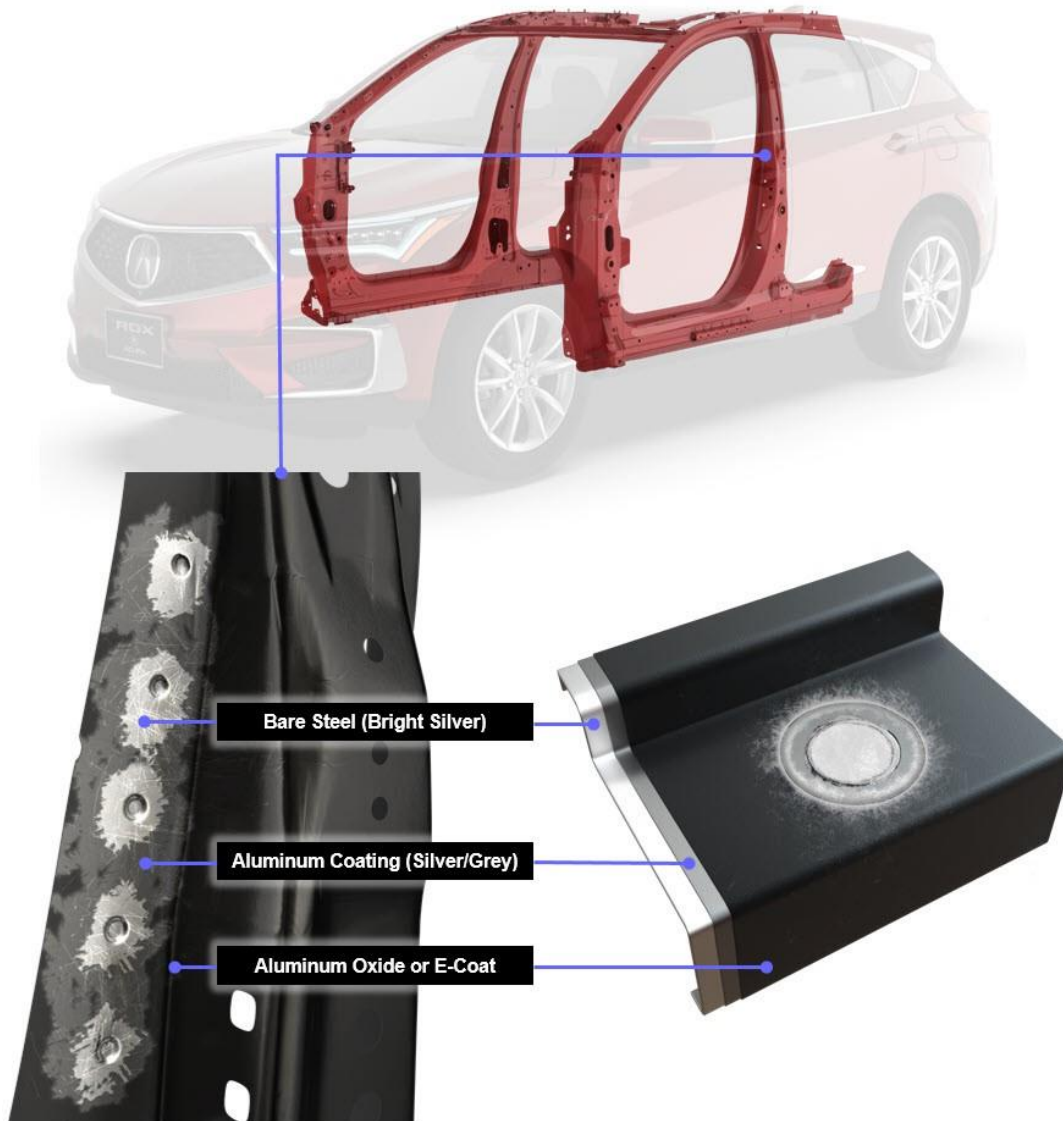

SPOT WELDING CONDITIONS FOR 1,500 MPA ULTRA HIGH-STRENGTH STEEL PARTS

When spot-welding 1,500 MPa steel parts, you must manually set the welder to the conditions listed below. The required welding conditions will be noted in the model specific body repair manual.

NOTE

For the actual settings of the welder, refer to the specifications supplied by the welder manufacturer.

Spot Welding Conditions							
Condition No.	Welding current A	Welding time ms	Applied force N (kgf)	Condition No.	Welding current A	Welding time ms	Applied force N (kgf)
1	6500	300	2452 (250)	21	9000	800	3432 (350)
2	7000	300	2452 (250)	22	9500	800	3432 (350)
3	7500	300	2452 (250)	23*	10500	700	3432 (350)
4	6500	400	2942 (300)	24*	10500	800	3432 (350)
5	7000	400	2942 (300)	25*	8000	1500	3432 (350)
6	7500	400	2942 (300)	26*	8000	800	3432 (350)
7	8000	400	2942 (300)	27	8500	1500	3432 (350)
8	7000	500	3432 (350)	28	7500	800	3432 (350)
9	7500	500	3432 (350)	29	8000	1200	3432 (350)
10	8000	500	3432 (350)	30	8500	1200	3432 (350)
11	8500	500	3432 (350)	31	9000	1200	3432 (350)
12	7500	600	3432 (350)	32	7800	700	3432 (350)
13	8000	600	3432 (350)	33	8400	700	3432 (350)
14	8500	600	3432 (350)	34	8800	700	3432 (350)
15	9000	600	3432 (350)	35	9000	700	3432 (350)
16	8000	700	3432 (350)	36	7800	1000	3432 (350)
17	8500	700	3432 (350)	37	8400	1000	3432 (350)
18	9000	700	3432 (350)	38	8800	1000	3432 (350)
19	9500	700	3432 (350)	39	9000	1000	3432 (350)
20	8500	800	3432 (350)				

NOTES

- Condition numbers with an asterisk are currently not used by any Acura models at the time of this publication.
- The condition numbers of the above list show the type of the spot welding conditions of the spot welding points including the ultra-high-strength steel (1,500 MPa/1,180 MPa) parts of Acura vehicles.
- The welding condition values described in the above list are determined by experiments using test pieces, zinc primer coating, preheat, and specified tip shapes (Round-16).

- For spot welds involving 1,500 MPa steel parts, manual spot welder settings provided in the model specific body repair manual or other Acura service information are required. Acura does not recommend using the spot welder's AUTO mode for this steel grade because these settings may not achieve adequate weld strength.

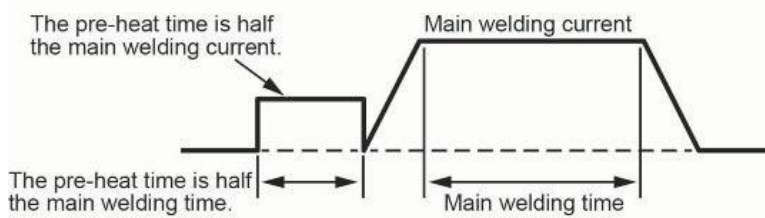

SHIELDING GAS REQUIREMENTS

NOTE

In this publication and the body repair manuals, gas metal arc welding (GMAW) is referred to by the following subtypes:

MIG Welding/Brazing = Metal Inert Gas (MIG) Welding/Brazing

- Argon is inert and does not react with the molten weld pool or brazing operation.
- The required MIG brazing shielding gas is 100% argon (Ar).

MAG Welding = Metal Active Gas (MAG) Welding

- The preferred shielding gas is C20. A mixture of 80% argon (Ar) and 20% carbon dioxide (CO₂), C20 produces a more stable arc, less weld spatter, and better weld quality/appearance.
- C25 shielding gas, a mixture of 75% argon (Ar) and 25% carbon dioxide (CO₂), is also acceptable. These are considered active gases because CO₂ undergoes a limited reaction with the molten weld pool.

USE OF HEAT DURING BODY STRAIGHTENING AND REPAIR

When you are doing body straightening and repair procedures, follow these guidelines:

- Never use open flame to heat body panels. However, use of induction heaters, copper stamp or heat guns are acceptable up to 1,100°F (600°C).
- Any parts that had heat applied above 1,100°F (600°C) degrees **must** be replaced with a new parts.
- Ignoring these instructions may significantly reduce occupant protection in any subsequent collision.

PARTIAL PANEL REPLACEMENT AT FACTORY SEAMS

The following guidelines **do not** apply to ultra-high-strength steel assemblies (980-1,500 MPa) such as the front door ring (outer stiffener ring) and some rear frame rails. These panels should never be disassembled and partially installed. Assemblies must be replaced as a complete set.

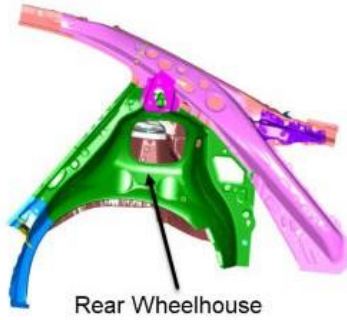

Rear Inner Panel Service Part Example

When you are determining whether to replace a body part as supplied, or do a partial replacement at the factory seams, follow these guidelines:

- Replacement of body service parts as supplied at factory seams is the preferred repair method, except when it may cause unnecessary or excessive intrusion into the body structure.
- In these cases, the service part may be disassembled at factory seams as required to replace only the damaged portion.
- For example, if only the vehicle's rear wheelhouse is damaged, that part may be removed from the rear inner panel service part assembly at the factory seams and installed on the vehicle.
- Replacement procedures for rear inner panels are not provided in the body repair manuals because they are rarely installed as a complete unit.
- All basic welding and sectioning guidelines specified in available service information must be observed during partial panel replacement.

STEEL PARTS SECTIONING GUIDELINES

Replacement of steel parts at factory seams and matching the replacement part configuration remain the preferred repair methods. However, these methods alone are not always practical nor cost effective in all body repair situations. While some limited sectioning procedures are provided in the body repair manual, it is not possible to develop published procedures covering every type and angle of impact. The guidelines detailed below are intended as "basic rules" for properly trained collision repair professionals to use when sectioning steel parts.

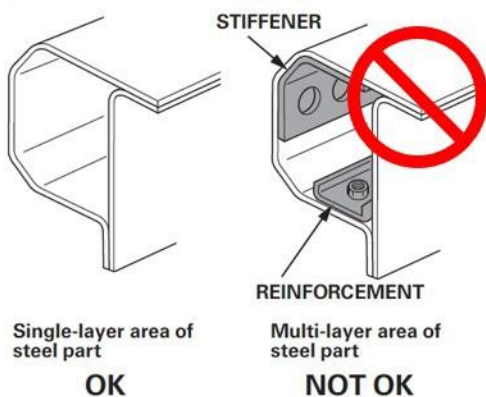

Sectioning Area Examples

Various high-strength and ultra-high-strength steel materials with different sheet thicknesses and strengths are applied in many places that vary with body design in order to increase collision safety performance, body stiffness, and weight reduction. Stiffening members are also applied inside some steel parts (patches, reinforcements, stiffeners, etc.)

Follow these guidelines to avoid an unsafe repair:

Outer Body Panels

- Outer body and floor panels with mild steel 270 MPa and low grade high-strength steel that is less than or equal to 590 MPa, may be sectioned as necessary.
- Every collision repair is different and requires sectioning to be done based on the nature of the repair which is why Acura does not provide a specific area to be sectioned. However, some areas like the outer rear panels and side sills show an area to be sectioned. This is a suggestion and not a requirement.
- For outer body panels sectioning locations, open butt welds with a 1 mm root gap is suggested and preferred as this is the best joint type for corrosion protection. If proper panel fit-up cannot be achieved, a 40 mm backing panel may be used.

All Panels

- Depending on the type of vehicle damage, steel parts with a tensile strength of 780 MPa or less may be sectioned if **all three** of the following conditions are met:
 1. Sectioning must be done in a single-layer area of the part.
 2. Multi-layer internal steel reinforcements and stiffeners must not be cut.
 3. Do not section in load bearing areas, such as engine, transmission, or suspension mounting points.
- To determine if a part has a single-layer area that can be sectioned, do the following:
 - Check the body construction pages in the General Information section of the appropriate body repair manual to determine the steel grade(s) and part configurations of the parts being replaced.
 - Inspect the original and replacement parts to confirm if there are internal reinforcements and/or stiffeners.
 - Spot welds not directly on a flange or joint indicate a reinforcement or stiffener inside.
 - The Replacement section of the body repair manual shows some internal reinforcements as a dotted line.
- If any of the above sectioning conditions cannot be met, replace those body structural components (stiffeners, reinforcements, and other multi-layered steel parts) as assemblies that match the replacement parts configuration.